

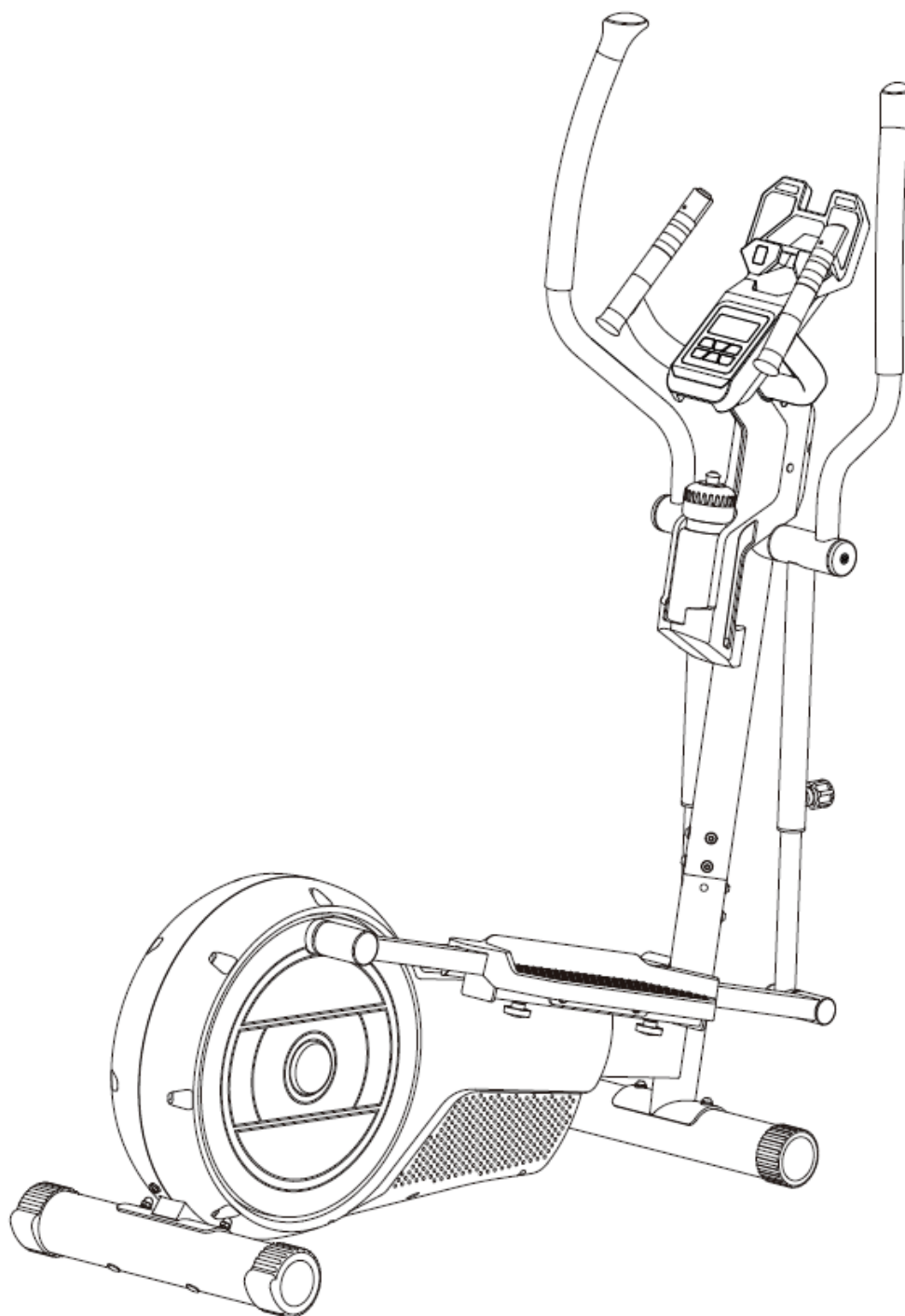

**USER MANUAL – EN**

**IN 27568 Elliptical Trainer inSPORTline ZenStride 300**



# CONTENTS

- SAFETY INSTRUCTIONS..... 3
- PARTS LIST ..... 4
- ASSEMBLY ..... 5
- CONSOLE ..... 10
  - BUTTONS ..... 10
  - DISPLAY ..... 11
  - PROGRAMS ..... 12
- iCARDIO APPLICATION ..... 20
- iCONSOLE APPLICATION ..... 25
  - SIGN IN ..... 26
  - HISTORY ..... 27
  - REST HR TEST ..... 28
  - SUPPORT ..... 29
  - SETTING ..... 30
  - QUICK START ..... 31
  - INTERVAL ..... 33
  - MAP MY ROUTE ..... 35
  - CONSTANT POWER ..... 36
  - PROGRAMS ..... 38
  - AI TRAINING ..... 40
  - GYM CENTER ..... 42
- USE OF ELEPTICAL TRAINER ..... 42
- EXERCISE INSTRUCTIONS ..... 42
- MAINTENANCE ..... 44
- ENVIRONMENT PROTECTION ..... 44
- TERMS AND CONDITIONS OF WARRANTY, WARRANTY CLAIMS ..... 44

SevenSport s.r.o. reserves the right to make any changes and improvements to its product without prior notice. Visit our website [www.insportline.eu](http://www.insportline.eu) where you will find the latest version of the manual.

## **SAFETY INSTRUCTIONS**

- Please read the manual before use and keep it for future reference.
- For safety reasons, perform regular checks to ensure that the device and its parts are not damaged or worn.
- If another person will be using the device, it is important that they are familiar with all the instructions given in this manual.
- Only 1 person can exercise on the device at the same time.
- Before using the device, check that all screws and nuts are properly tightened and that all joints are in good condition.
- Before exercising, remove all dangerous objects with sharp edges from around the device.
- Do not use the device if it is not completely in order and fully functional.
- A damaged, worn or defective part must be replaced with a new one as soon as possible. Do not use the device until it has been properly repaired.
- Parents and guardians are responsible for the safety of children. Children's curiosity and love of play can lead to dangerous situations.
- An elliptical trainer is not a toy.
- Sufficient free space must be ensured around the entire device.
- Improperly conducted or excessive exercise can endanger your health.
- After completing the assembly, check that the adjusting feet and other adjustable parts of the device are correctly adjusted.
- Place the device on a flat surface and ensure its stability.
- Wear appropriate clothing and shoes for exercise. Clothing that could get caught in the device during exercise (e.g. clothing that is too long and loose) is not suitable. We recommend sturdy sports shoes with non-slip soles.
- Consult your doctor before starting any exercise program. Your doctor can suggest a suitable exercise program and recommend a suitable diet.
- Assemble the trainer according to the instructions in the manual and use only the original supplied parts. Before starting assembly, check that all the parts listed in the parts list have been supplied.
- Place the device on a dry and flat surface and protect it from moisture. If necessary, place a suitable anti-slip mat under the device to prevent damage to the surface under the device.
- Exercise equipment and aids are not toys and should always be used correctly. Therefore, this device may only be used by persons who are familiar with its correct operation.
- Stop exercising immediately if you experience dizziness, nausea, chest pain, or any other physical discomfort. Consult your doctor about further exercise.
- Children and disabled people can only exercise on the device under the supervision of a qualified person who will ensure the correct exercise procedure.
- Be careful when exercising and be careful not to injure yourself or the people around you by the moving parts of the device.
- All adjustable parts of the device must be set correctly with regard to their extreme positions.
- Do not exercise immediately after eating.
- Category - HC intended for home use.

- Load capacity: 150 kg
- **WARNING!** The heart rate monitoring system may not be accurate. Overexertion during training can cause serious injury or death. If you feel nauseous, stop exercising immediately!

## PARTS LIST

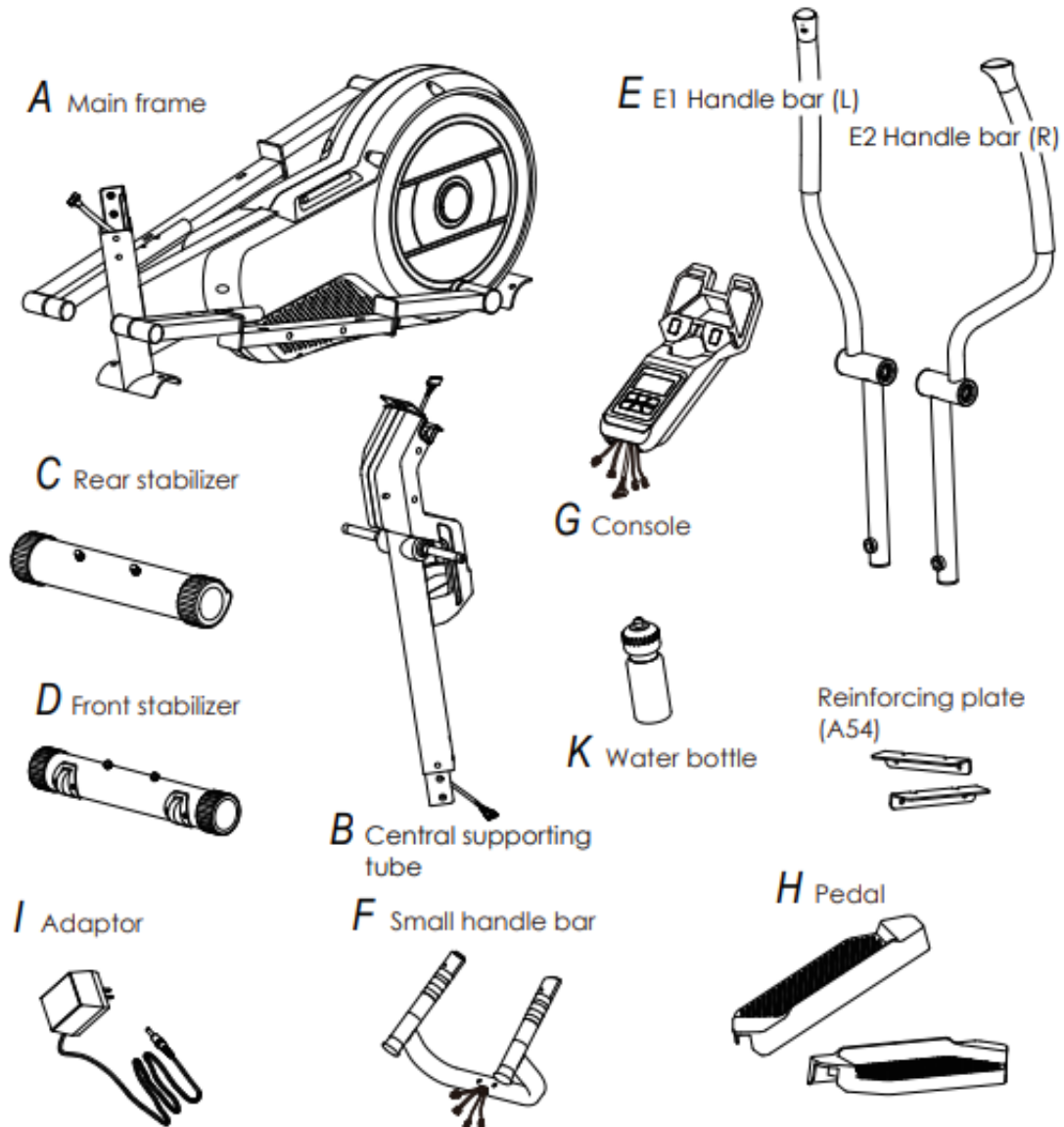

### J

(J7) Washer M8



(J11) Washer M6



(J8) Wave washer D17



(N2) Screw M8x20L



(J10) Spring washer M6



(H1) Knob



(E4) Knob



(N1) End cap



### Tool

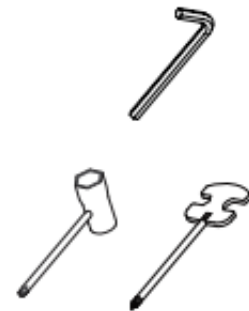

## ASSEMBLY

Remove the nuts (J1), spring washers (J2), washers (J3), and screws (J17) from the rear stabilizer (C).

Attach the rear stabilizer (C) to the main frame (A) using the nut (J1), spring washer (J2), washer (J3), and screw (J17).

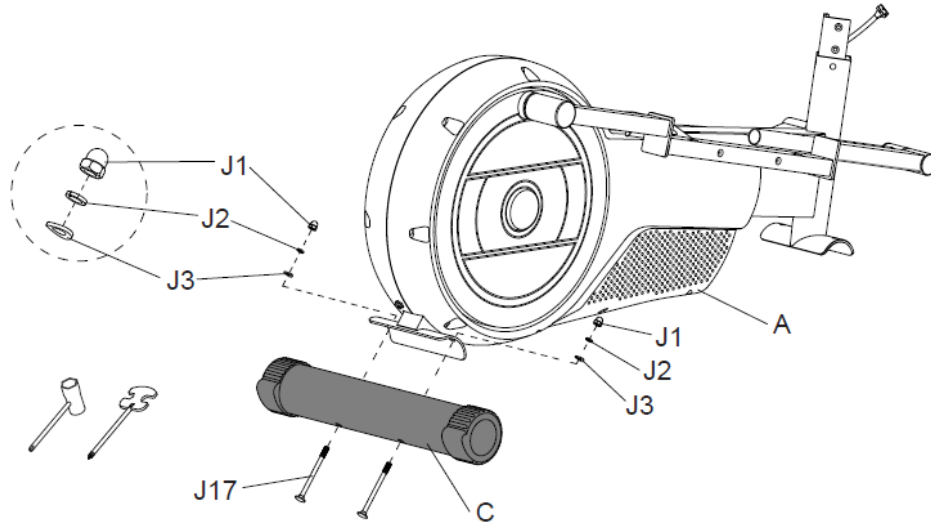

Remove the bolts (J4), washers (J5), and spring washers (J15) from the main frame (A).

Connect the sensor cables (L1 and L2). Then slide the handle post (B) into the main frame (A) and secure with screws (J4), washer (J5) and spring washer (J15).

Be careful not to pinch the cables.

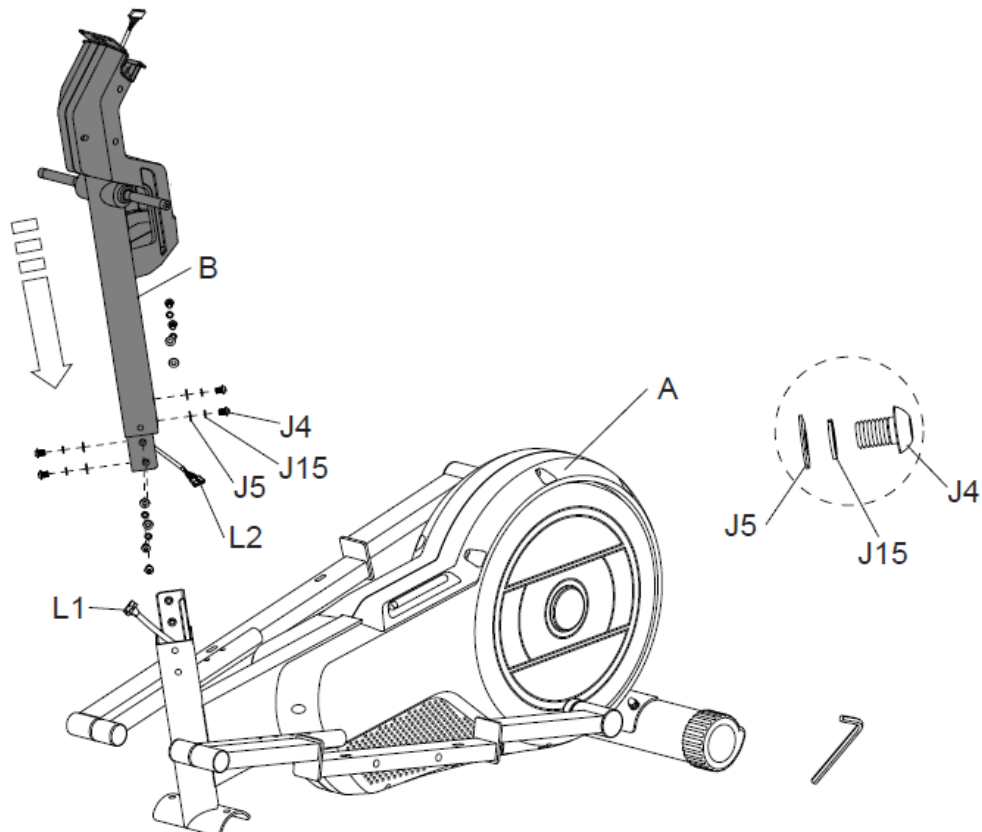

Slide the washers (J8) onto the column axes. Slide the handle (E2) onto the axle, then secure with the washer (J7), cap (N1), and bolt (E1).

Repeat on the other side.

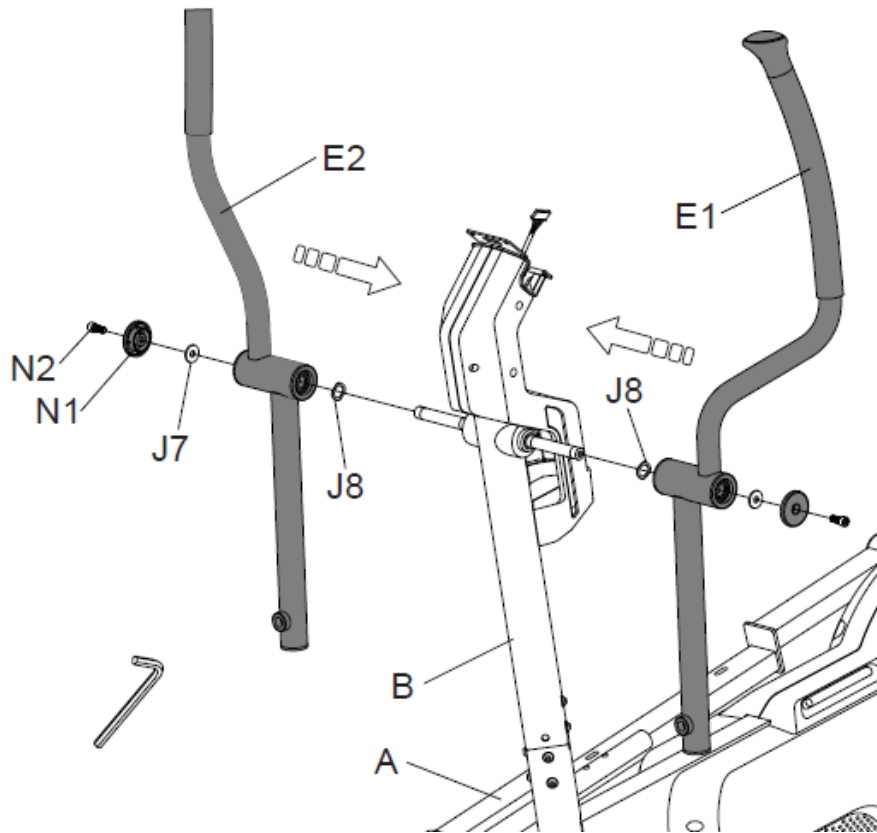

Connect the pedals to the handles using the hand knob (E4). Set the sides evenly. Make sure you tighten the hand knob.

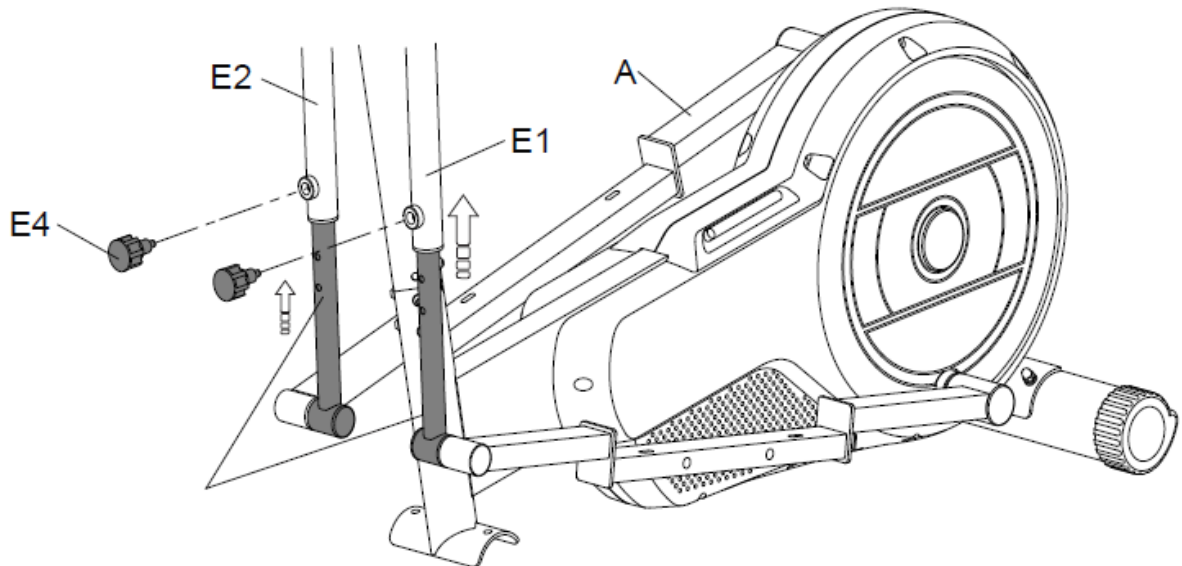

Unscrew the bolts (J9), spring washers (J2), and washers (J3) from the front stabilizers (D).

Attach the front stabilizer (D) to the main frame (D) and secure with bolts (J9), spring washers (J2), and washers (J3).

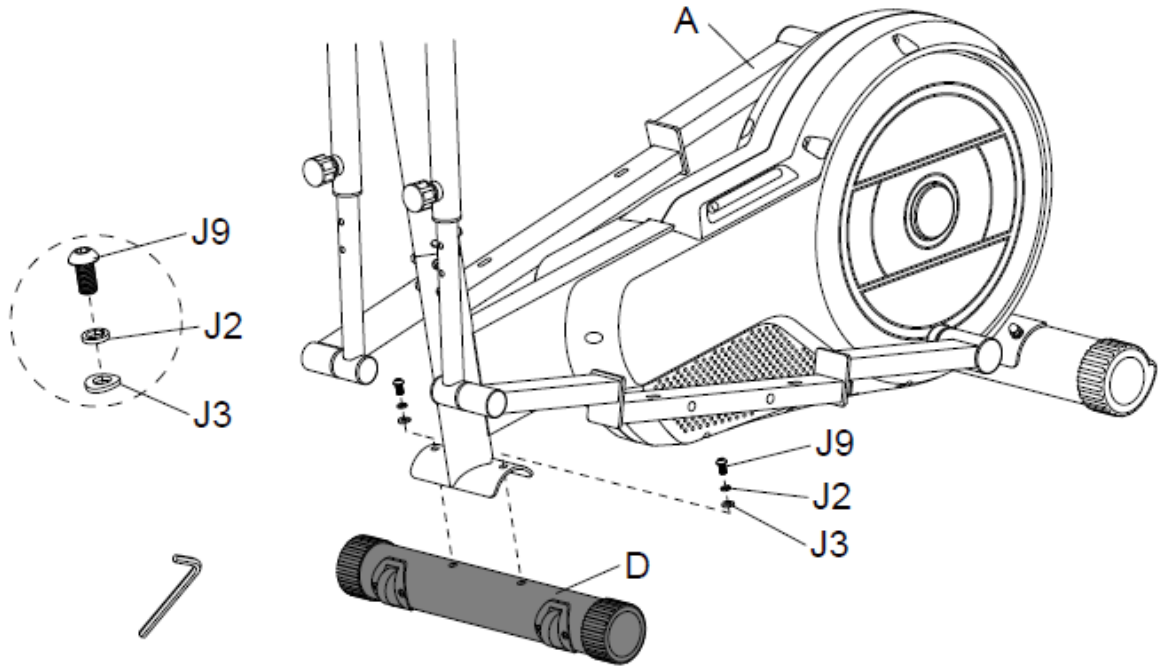

Unscrew the bolts (J9), spring washers (J2), washers (J5) from the pedal frame (A49).

Attach the reinforcement plate (A54) to the pedal frame (A49) with screws (J9), spring washer (J2), washer (J5).

Attach the pedals (H) with hand screws (H1), spring washers (J10), and washers (J11).

Repeat for the other side.

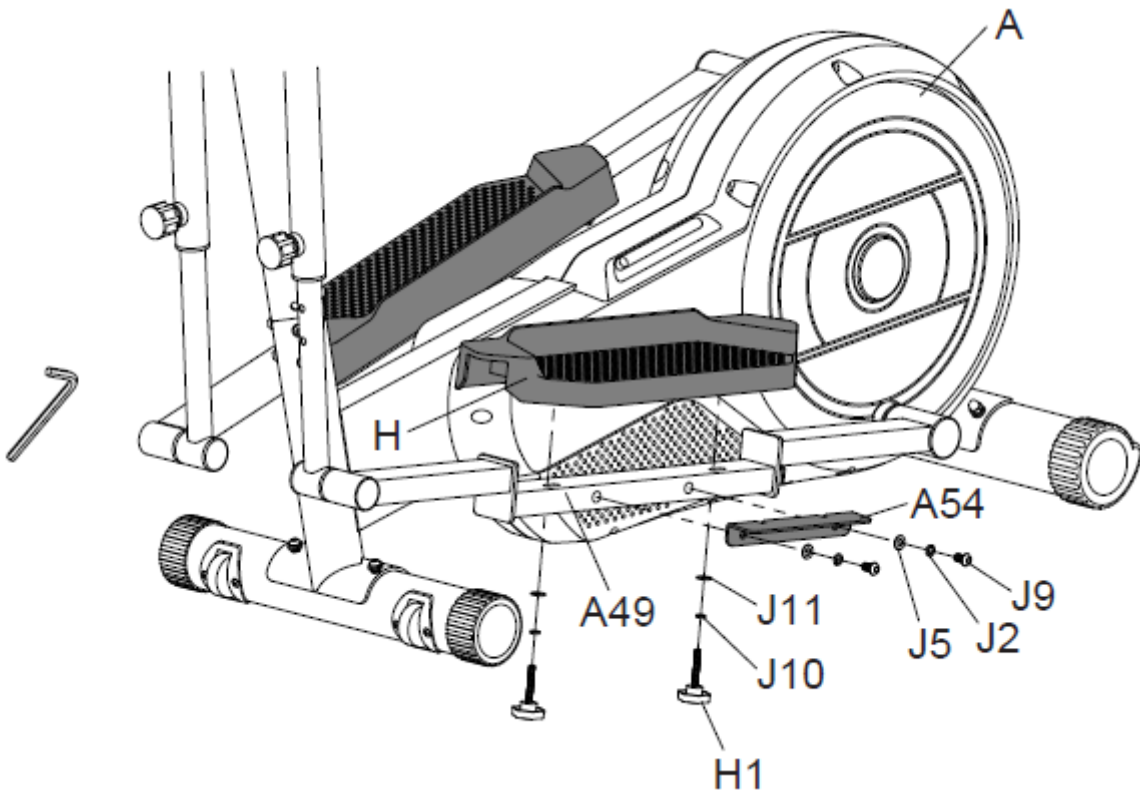

Remove the washers (J13) and nuts (J14) from the handle post (B). Screw the handles (F) to the handle post (B) using washers (J13) and nut (J14).

Be careful not to pinch the cables.

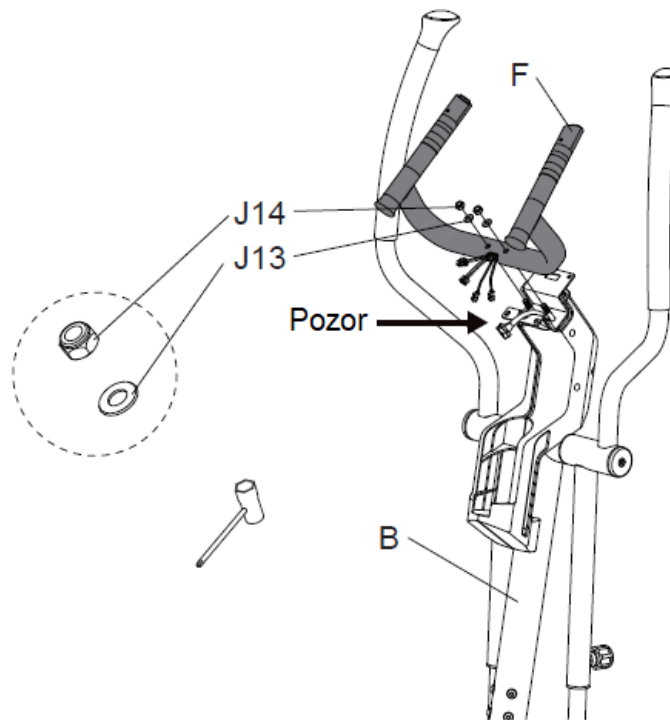

Unscrew the bolts (G1) from the console (G). Connect the cables (L2, L3, L4, L5).

Attach the console (G) to the console bracket with removed bolts (G1). Be careful not to pinch cables.

You can level the trainer using the leveling feet (C2 and C3).

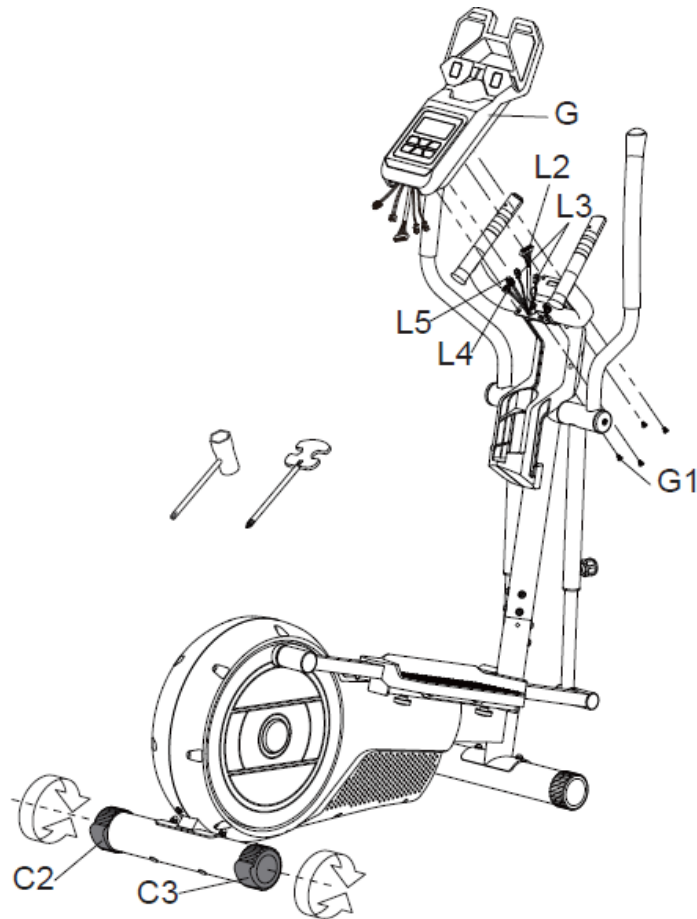



Place the bottle (K) in the holder (A).

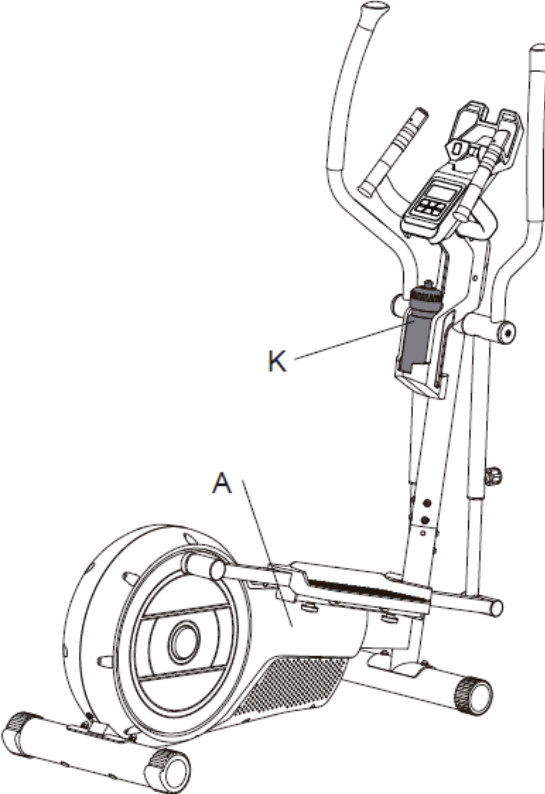

You can move the trainer by tilting it on the wheels on the front stabilizer. Always ask another person for help.

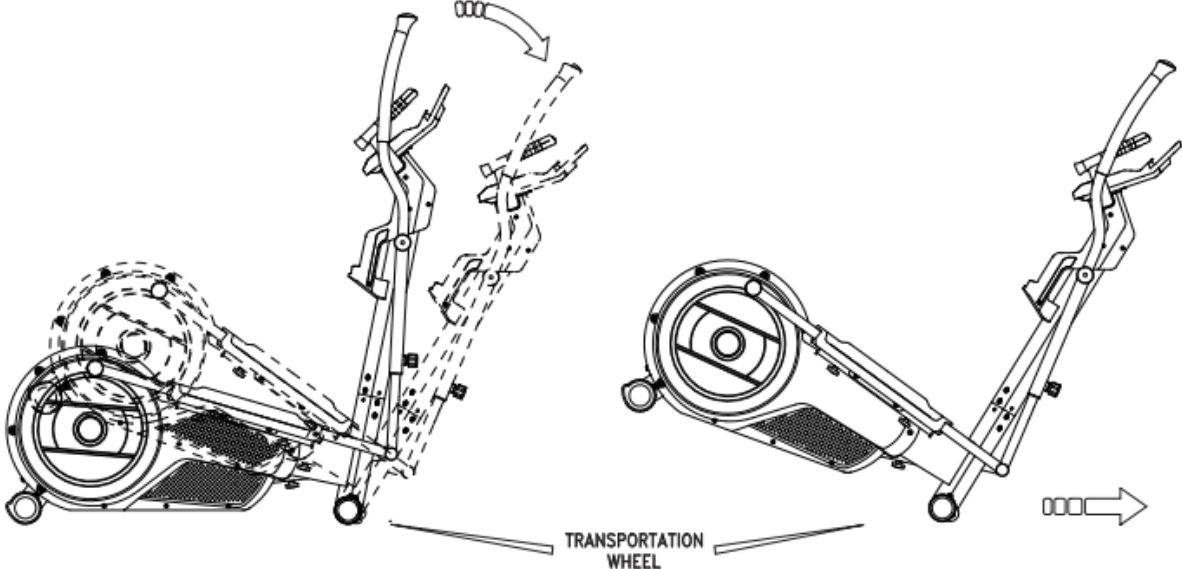

# CONSOLE



# BUTTONS

Button	Function
UP (+)	Increasing the value of e.g. load, performance, time Navigation button
DOWN (-)	Reduction of the value of e.g. load, power, time Navigation button
MODE	Selecting a function or setting
RESET	Hold for 2 seconds to restart the console Press the button to return to the main menu if the program is paused
START/STOP	Start or stop a program
RECOVERY	Heart rate recovery test

## DISPLAY

Function	Description
SPEED	Current speed Range: 0.0 ~ 99.9
RPM	Revolutions per minute Range: 0~999
TIME	Exercise time Range: 0:00 ~ 99:59
DISTANCE	Distance Range: 0.0 ~ 99.9
CALORIES	Burned calories Range: 0~9999
WATT	Power Range: 0~999
PULSE	Pulse Range: 0-30~230
U1~U4	U1 ~ U4 profiles Gender: male / female Age (A): 1 ~ 99 (original value 25) Height (H): 100 ~ 200 (original value 160) (cm) Weight (W): 20 ~ 150 (original value 50) (kg)
MANUAL	Manual program
WATTS	Power program, resistance changes depending on target power / rpm
H.R.C	Target heart rate program, the resistance changes depending on the target heart rate
USER	Create profiles, max 4
PROGRAM	Selection of 12 preset programs
RESISTANCE	Range: 1~16
BLUETOOTH	Yes

## PROGRAMS

### TURN ON

- Plug in the power (or hold RESET for 2 seconds), the console will start, and the display will show all segments for 2 seconds (Fig. 1).
- The LCD display will display the wheel diameter, the unit (Km or mile) for 1 second (Fig. 2), the resistance will be set to 1 level.

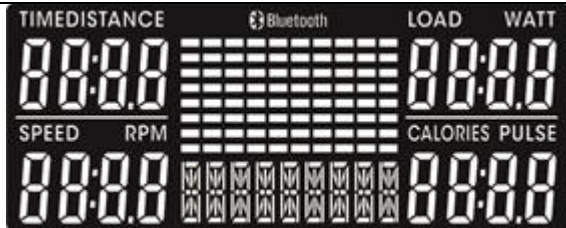

Fig. 1



Fig. 2

### PROGRAM SELECTION

- It is necessary to select the user program U1 ~ U4 (Fig. 3), then it is necessary to set the gender, age, height, weight (Fig. 4 ~ 7), then select the program (Fig. 8).

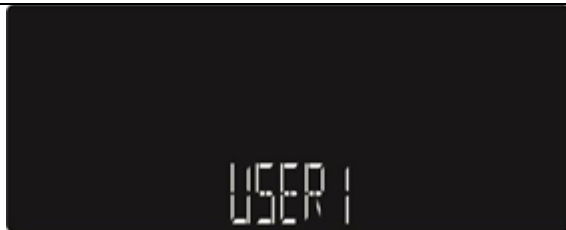

Fig. 3



Fig. 4

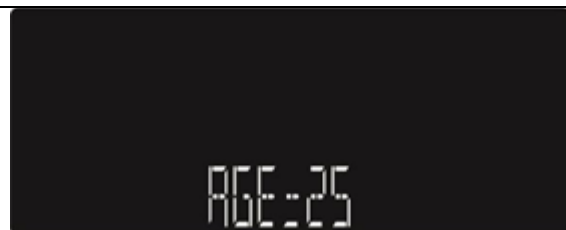

Fig. 5

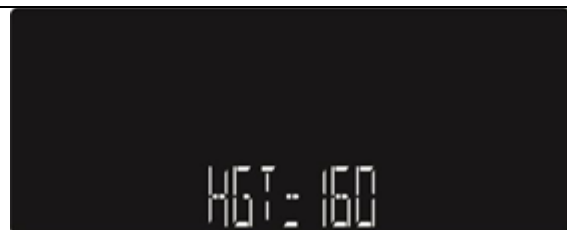

Fig. 6

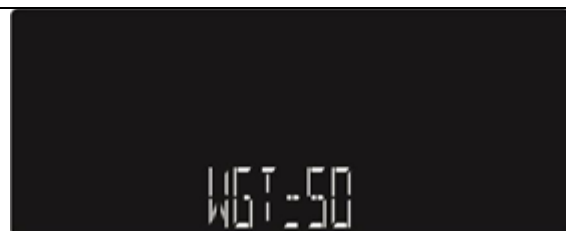
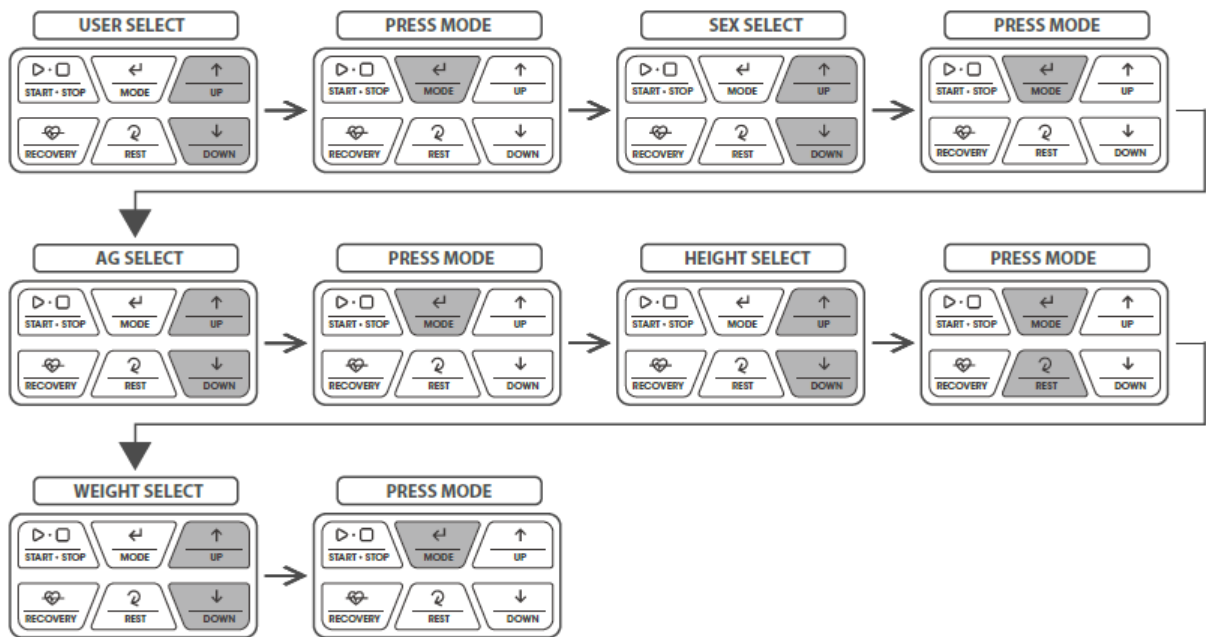

Fig. 7



- The LCD display will show MANUAL (Fig. 8), the user can use the navigation buttons to select programs WATT (Fig. 9) – H.R.C (Fig. 10) – USER (Fig. 11) – PROGRAM (Fig. 12) – MANUAL. Confirm program selection by pressing MODE.

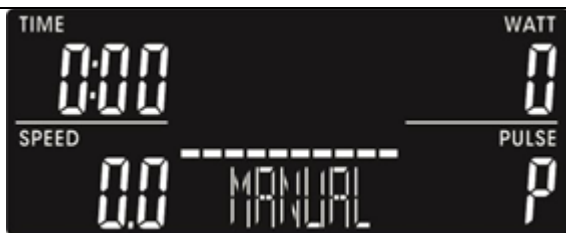

Fig. 8



Fig. 9



Fig. 10



Fig. 11



Fig. 12

## Manual program

- Press START/STOP to start the program immediately.
- Use the navigation buttons to select MANUAL, confirm the program by pressing MODE/ENTER.
- Press the navigation buttons to set the load (fig. 13), confirm the load by pressing MODE.
- Using the navigation buttons, you can set target values for: time (Fig. 14), distance (Fig. 15), calories (Fig. 16), heart rate (Fig. 17).
- Press STAR/STOP to start the program (Fig. 18). The user can set the load during the exercise. The current load is shown on the display.
- You can pause the program during the exercise by pressing START/STOP, all values will be displayed. The pulse will continue to be detected. Press RESET to return to the main menu.

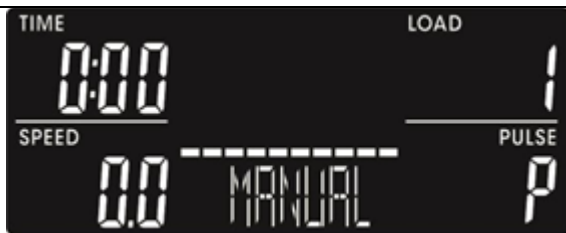

Fig. 13

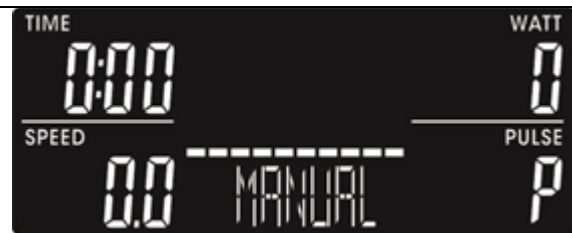

Fig. 14



Fig. 15



Fig. 16



Fig. 17

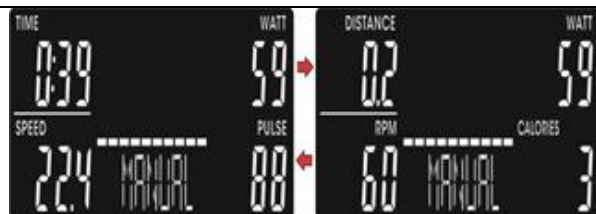
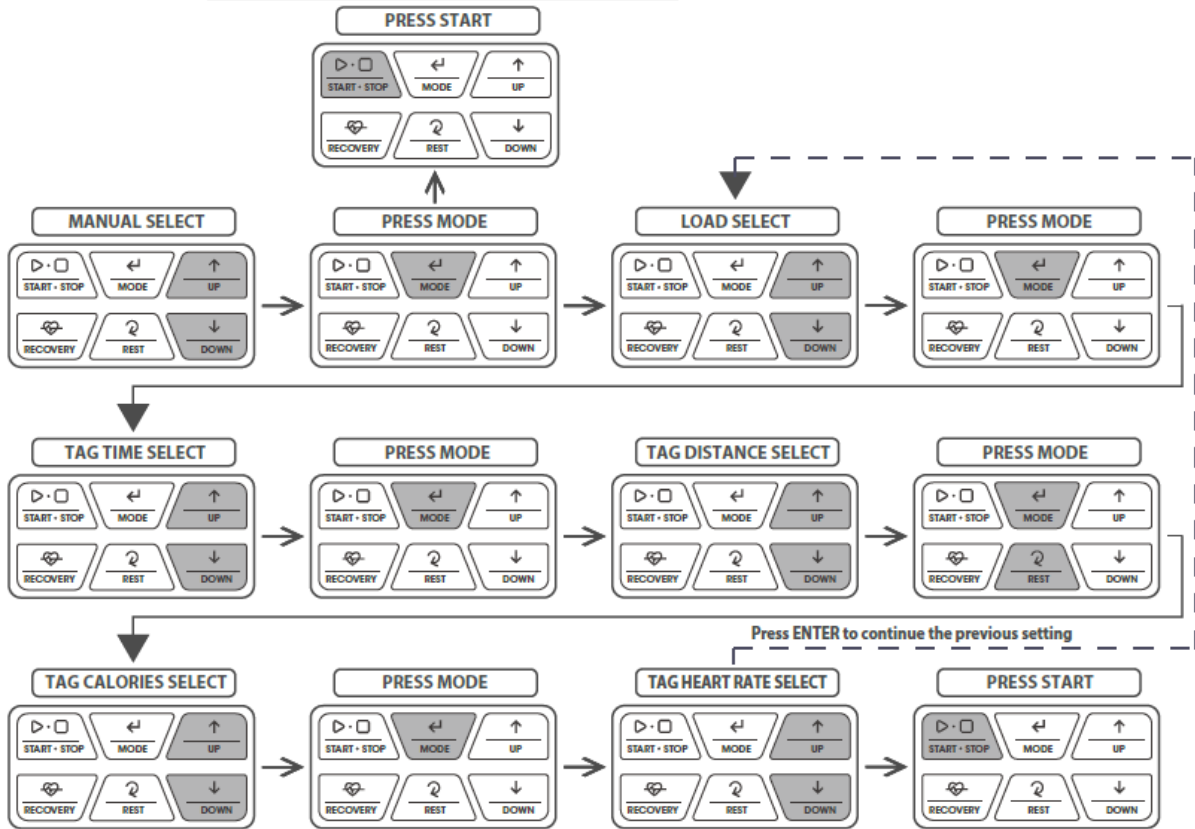

Fig. 18

Press START to get started, do not set up any target value.



### WATT program

- Use the navigation buttons to select the WATT program, confirm by pressing MODE (fig. 9).
- The WATT value will flash, set the value (the original value is 120, Fig. 19). Adjust the value using the navigation buttons. Press MODE to confirm the value. You will pass the time setting.
- Use the navigation buttons to set the time, press START/STOP to start the program.
- After starting, the load will be adjusted according to the set value of the target power. The user can also change the value using the navigation buttons.
- You can pause the program during the exercise by pressing START/STOP, all values will be displayed. The pulse will continue to be detected. Press RESET to return to the main menu.



Fig. 19

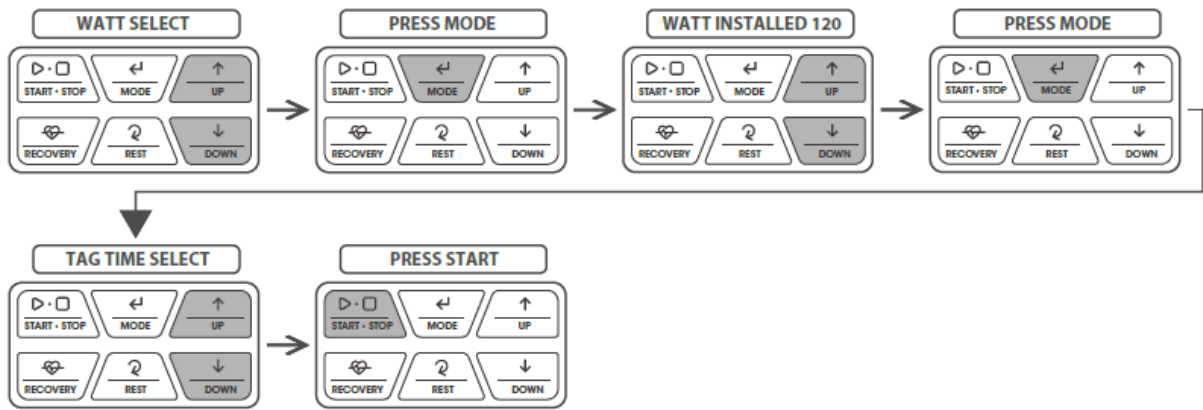

### HRC program

- Use the navigation buttons to select the HRC program (Fig. 10). Confirm by pressing MODE.
- Use the navigation buttons to select the values 55%, 75%, 90% and TARGET (Fig. 20 ~ 23). The original value is calculated from the entered age in the profile and will be displayed on the PULSE display.
- Use the navigation buttons to set the target value (30~230). Then press MODE. Go to time settings.
- Use the navigation buttons to set the time. After setting the time, press STAR/STOP, the load will change according to your current heart rate.
- You can pause the program during the exercise by pressing START/STOP, all values will be displayed. The pulse will continue to be detected. Press RESET to return to the main menu.



Fig. 20



Fig. 21



Fig. 22



Fig. 23

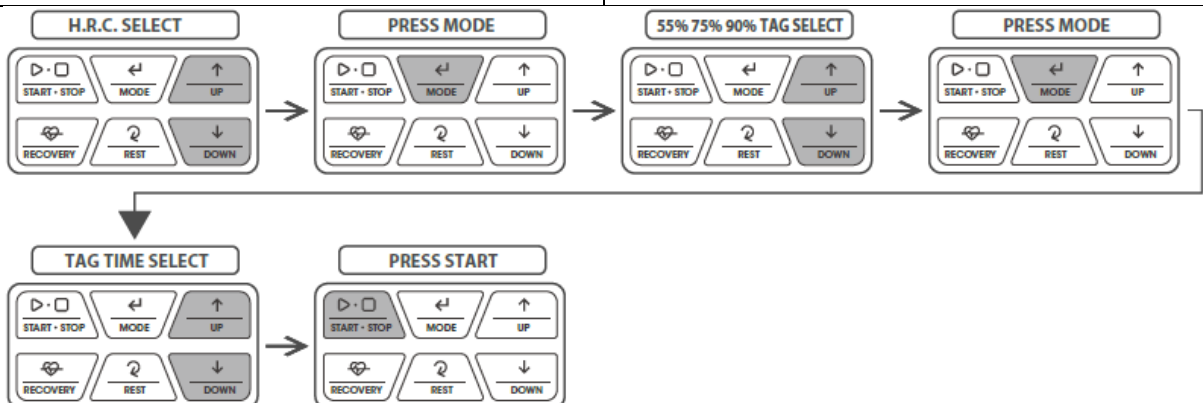



## USER program

- Use the navigation buttons to select USER (fig. 11), confirm by pressing MODE (fig. 24).
- Use the navigation buttons to set the load (Fig. 25). Each value must be confirmed by pressing MODE. 10 segments need to be set. After setting all 10 segments, it is necessary to set the training time. If you do not set the load of all segments, the values from the last setting will be used.
- Set the training time using the navigation buttons.
- Press STAR/STOP to start the program. The user can set the load during the exercise. The current load is shown on the display.
- You can pause the program during the exercise by pressing START/STOP, all values will be displayed. The pulse will continue to be detected. Press RESET to return to the main menu.



Fig. 24



Fig. 25

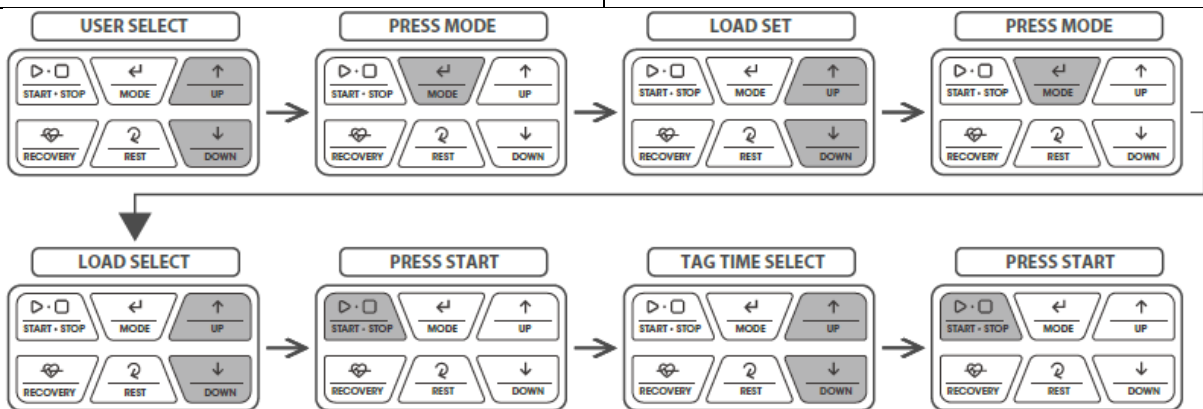

## 12 PRESET PROGRAMS

- Use the navigation buttons to select PROGRAM (fig. 12) and confirm by pressing MODE.
- Then select program P01, P02, P03, P04, ....., P12 (the programs are graphically indicated below).
- After selecting the program, the load values will flash, the original value is 1 (Fig. 27). You can adjust the value using the navigation buttons and confirm by pressing MODE.
- You can set values for time, distance, calories and heart rate.
- Press STAR/STOP to start the program. The user can set the load during the exercise. The current load is shown on the display.
- You can pause the program during the exercise by pressing START/STOP, all values will be displayed. The pulse will continue to be detected. Press RESET to return to the main menu.



Fig. 26



Fig. 27

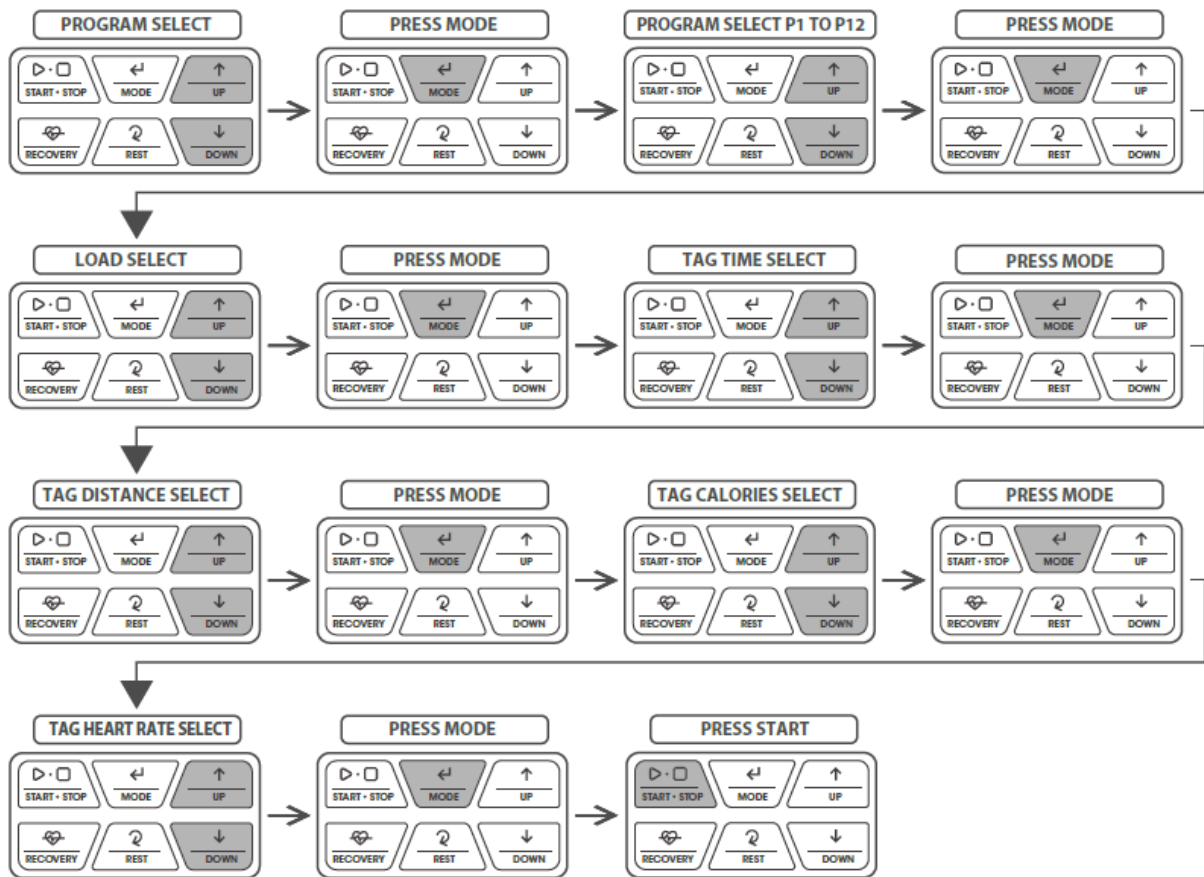

### RECOVERY program

- After your workout, wear the chest strap or grab the heart rate sensors and press RECOVERY. A countdown starts from 00:60 to 00:00 (Fig. 28). After the calculation is completed, the result F1 ~ F6 will be displayed (Fig. 29). F1 is the best result, F6 the worst.
- **WARNING!** A system for monitoring heart rate may not be accurate. Overloading during training may cause serious injury or death. If you feel any discomfort, immediately stop the exercise!

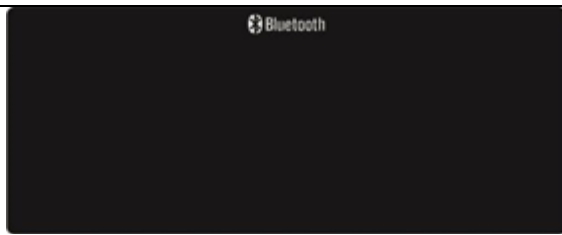

Fig. 28

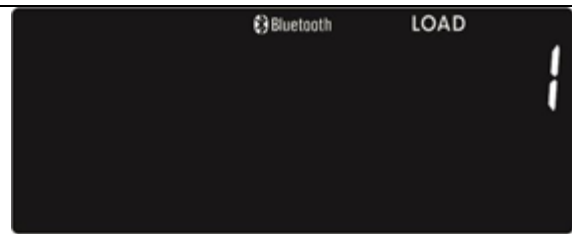

Fig. 29

## Bluetooth



Not connected (Fig. 31)



Connected (Fig. 32)

## Preset programs





## iCARDIO APPLICATION

- Download the iCARDIO app to your smart device.
- \*The application is compatible with Android 9 / iOS 13 and above systems



iOS



Android

- Start Bluetooth on your smart device.
- Start the application and enter the iCardio password, the password must be entered only the first time the application is launched.
- Pairing the iCardio app and the console
- Press the gear icon in the lower left corner.

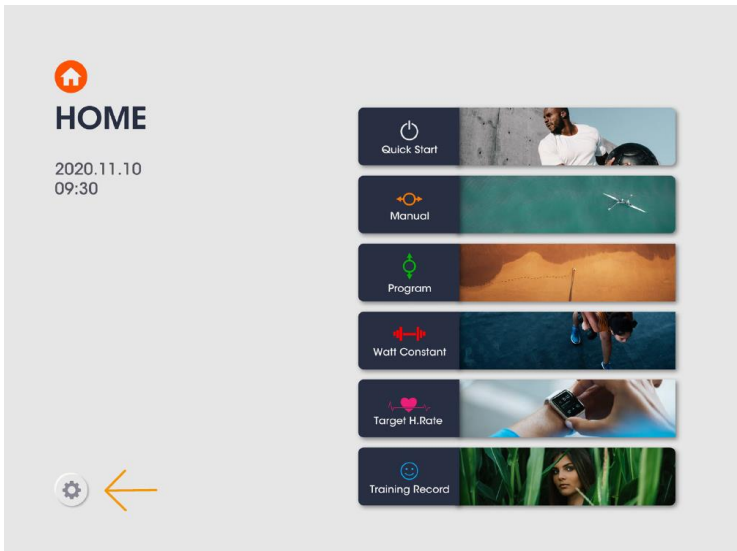

Tablet

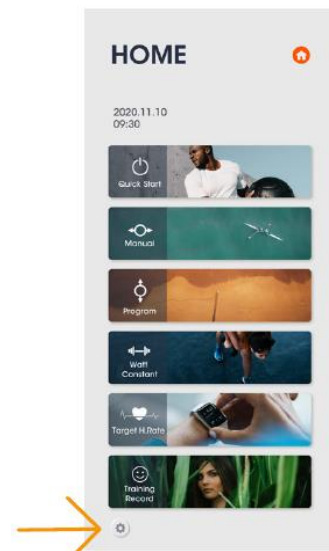

Smartphone

Select Bluetooth

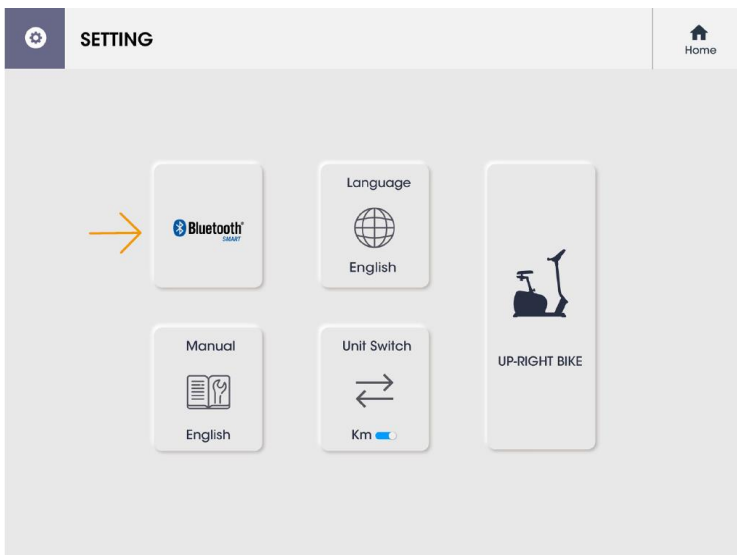

Tablet

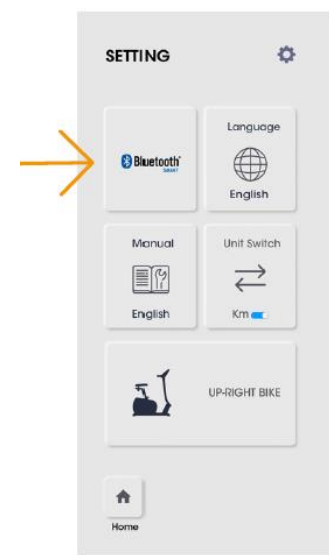

Smartphone

Check if the numbers on the back of the machine are identical to the number in the application, if so, confirm by pressing confirm.

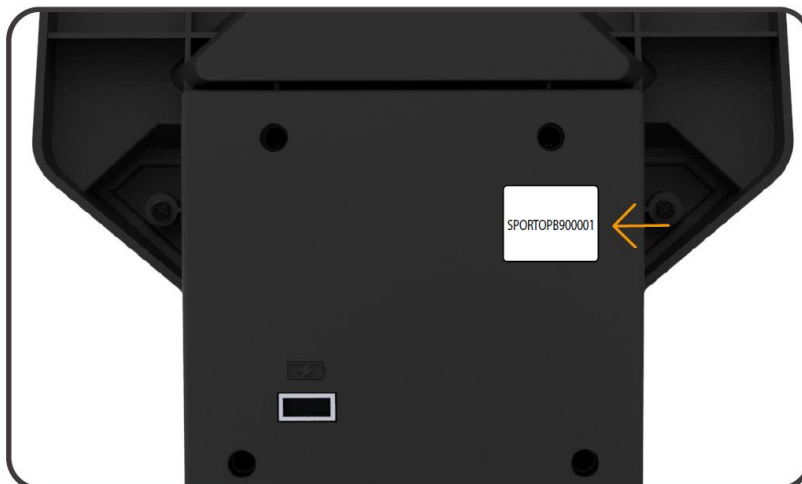

If the device does not appear in the application, try the following steps:

1. Press the arrow icon in the lower right corner.

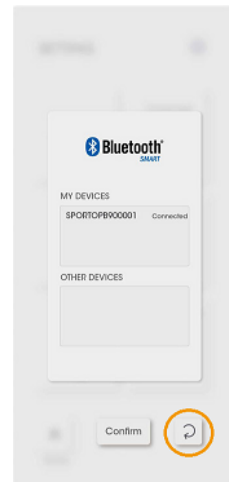

2. Unplug and plug in the machine adapter.



3. Restart your smart device.



\*Make sure Bluetooth is turned on on your smart device.

\*If none of the three options above work, contact the service center.

### Changing the language

Press the icon in the left-hand corner.

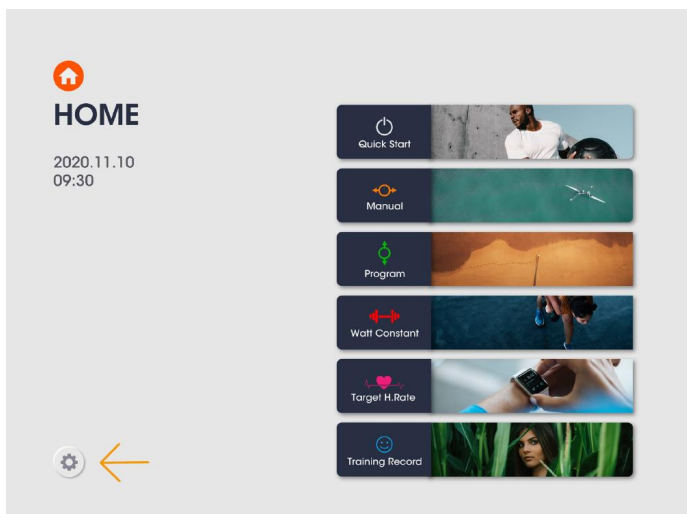

Tablet

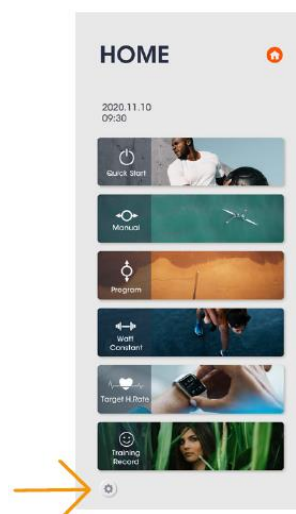

Smartphone

Press  and select language.

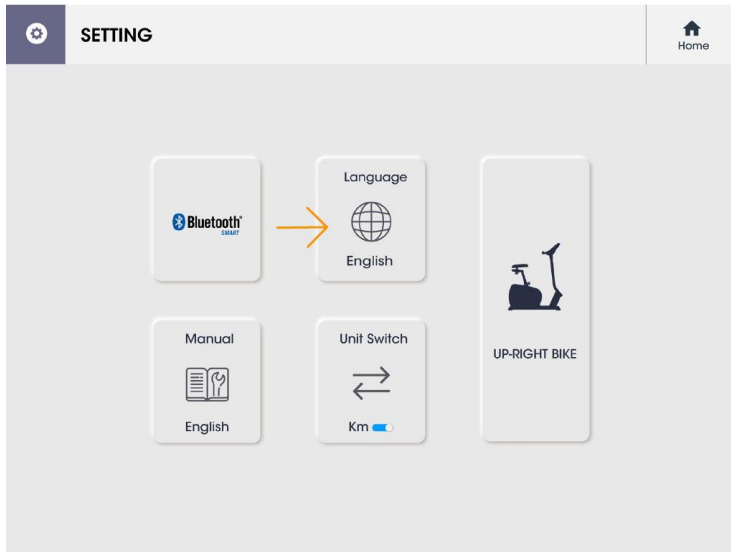

Tablet

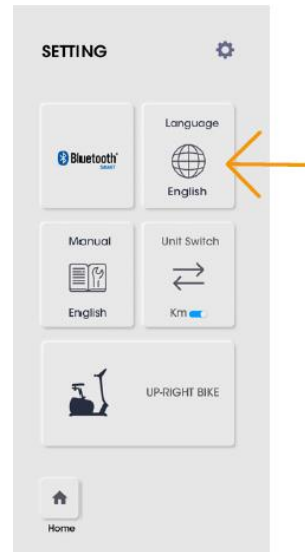

Smartphone

Manual for the iCardio application

Press the icon in the left-hand corner.

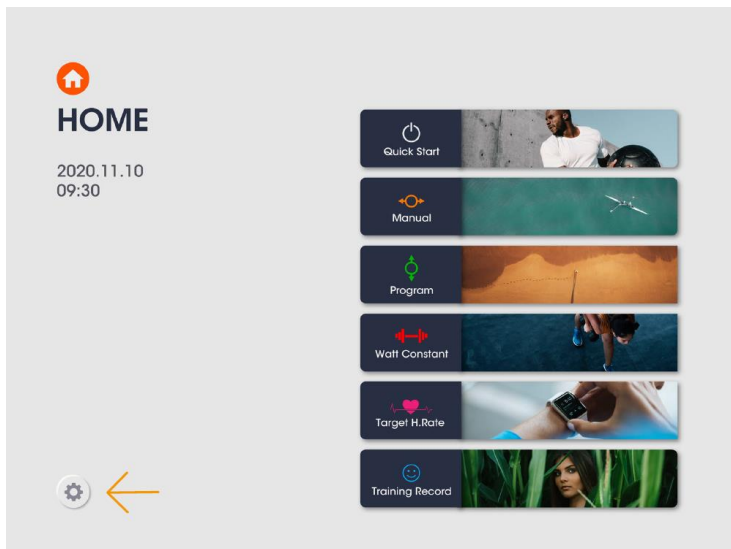

Tablet

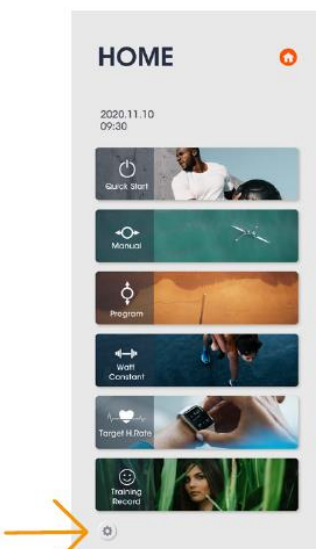

Smartphone

Press  .



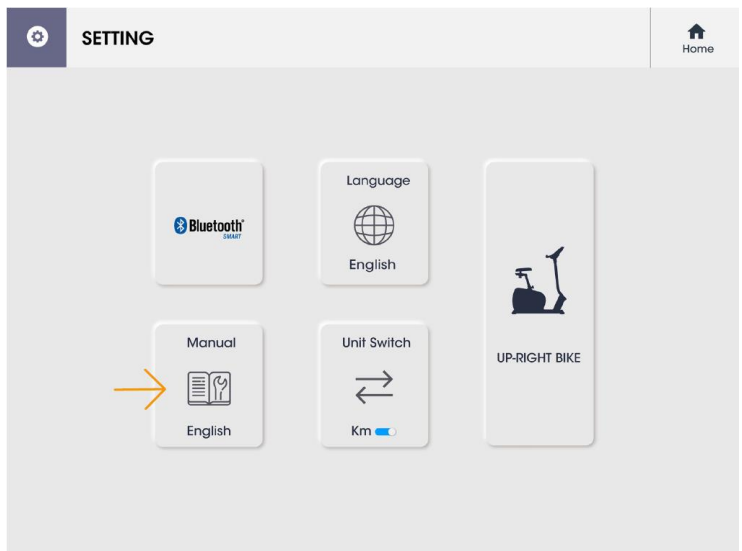

Tablet



Smartphone

\*The language of the manual changes according to the set language of the application.

Apart from the iCardio application, it is possible to pair the machine via Bluetooth with the KINOMAP and Zwift applications.

You can find apps in Google or Apple store. The applications are operated by a third party and the seller is not responsible for the operation or functionality of these applications.

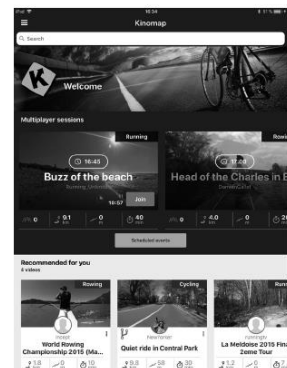
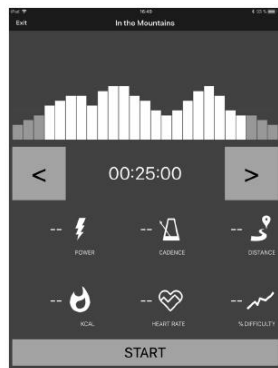

\*Once the app connects to the console, you will hear two short beeps.

\*Once the app disconnects from the console, you will hear one long beep.



# iCONSOLE APPLICATION



iOS



Android



In iConsole +, select MY TRAINING. Here you can see a summary of your training (total distance, total time, calories burned)

## SIGN IN

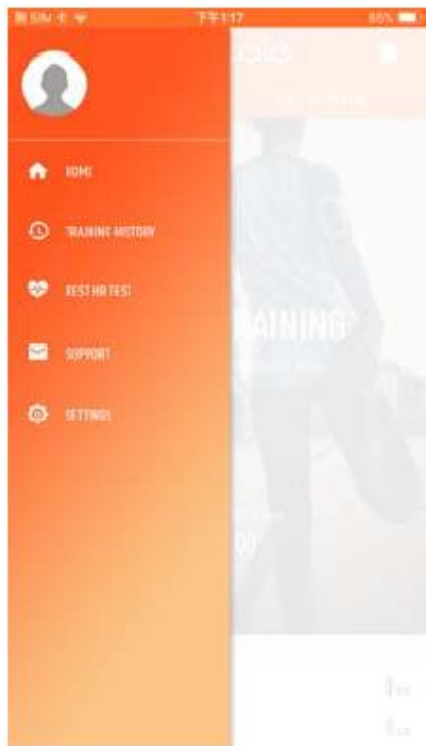

1. Choose your avatar on left side to enter profile settings



2. Log in with your Facebook, Gmail or WeChat account

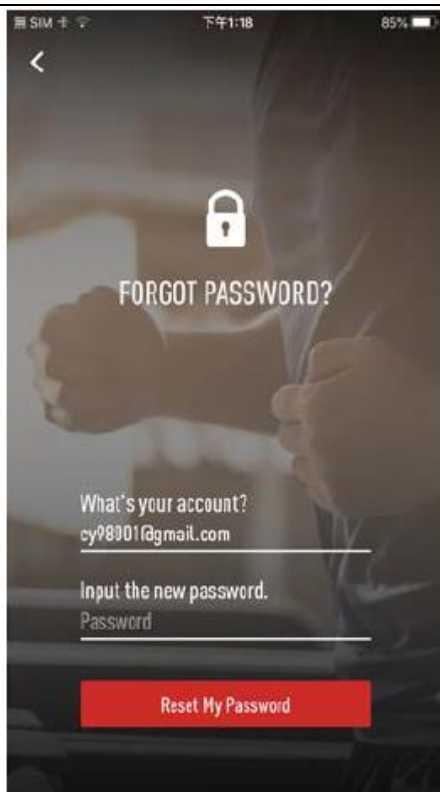

3. If you forgot your password you can choose Reset my password. Your new password will be send to your email.

## MEMBERSHIP

- Choose your profile picture to enter profile settings.
- You can change profile picture or update your profile information. (If don't enter all required information, calculated data may not be calculated correctly.)

## SIGN OUT

- Choose your profile picture to enter profile settings.
- Select the icon in the top right corner to sign out. (You can still **exercise** without signing in, but the data won't be saved.)

## HISTORY

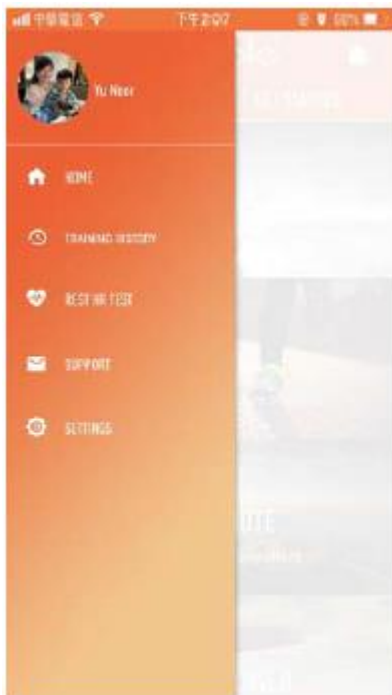

Select profile picture and then select TRAINING HISTORY.

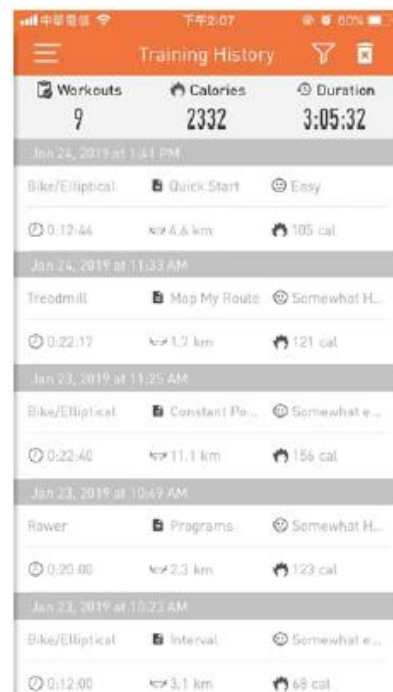

The measured data will be displayed: number of workouts, calories, training time and list of workouts.

Choose  to delete data.

Used device, program, RPM, time, distance and calorie data are recorded.

Select a workout to display the information.

Data from all devices and programs are stored.



## REST HR TEST

**WARNING!** A system for monitoring heart rate may not be accurate. Overloading during training may cause serious injury or death. If you feel any discomfort, immediately stop the exercise!

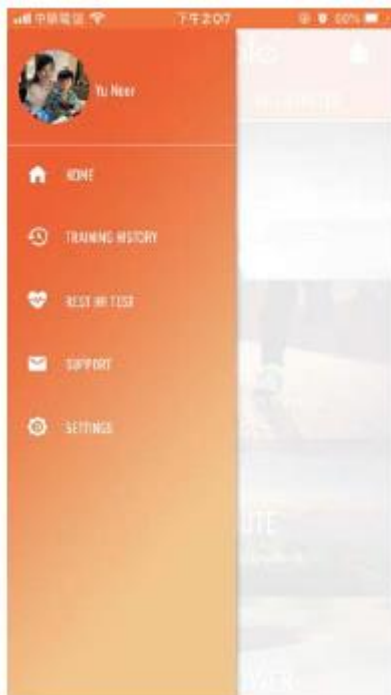

Select your profile picture to expand the menu.  
Select REST HR TEST.



Select source: Apple watch or BLE HRM

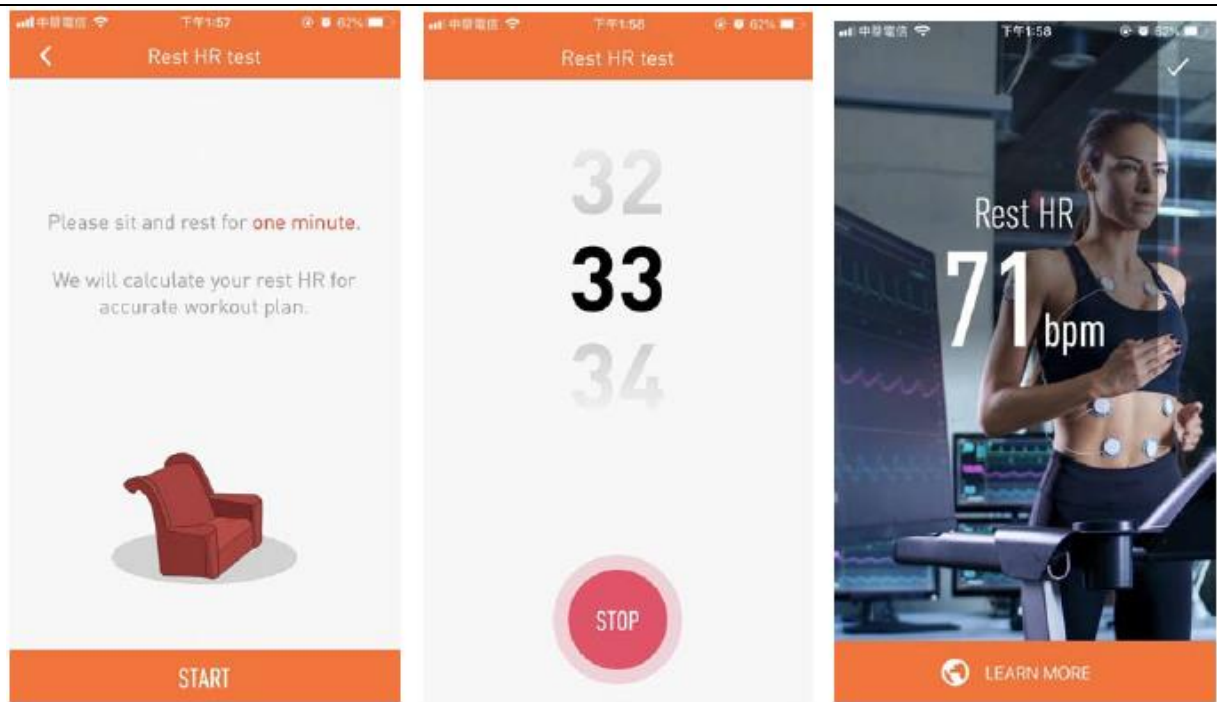

After connecting, select START and 60s countdown will begin. After the countdown, the rest heart rate is displayed at and the heart rate is calculated for the most accurate training program.

## SUPPORT

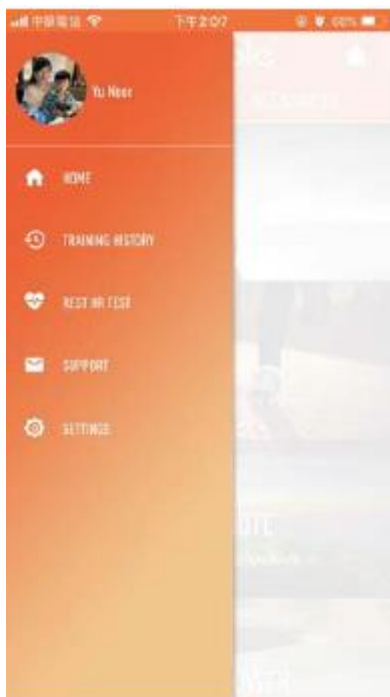

Select your profile picture to expand the menu.  
Select SUPPORT.

## SETTING

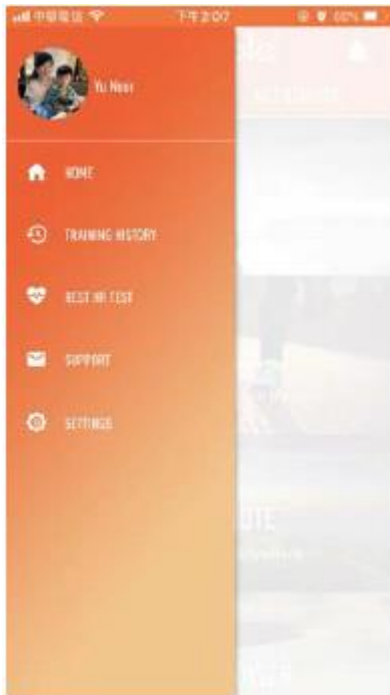

Select your profile picture to expand the menu.  
Select SETTING.

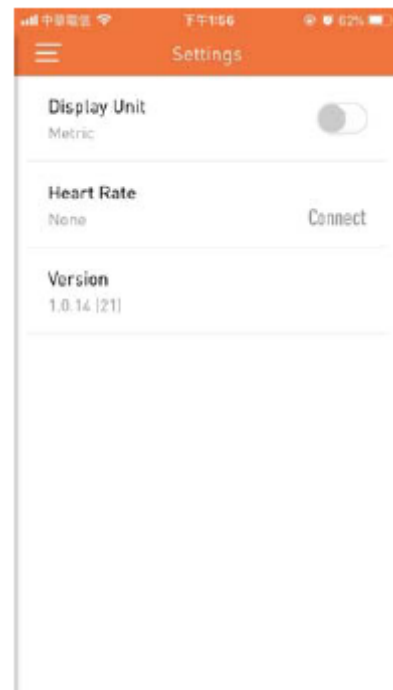

Select unit: metric or imperial.

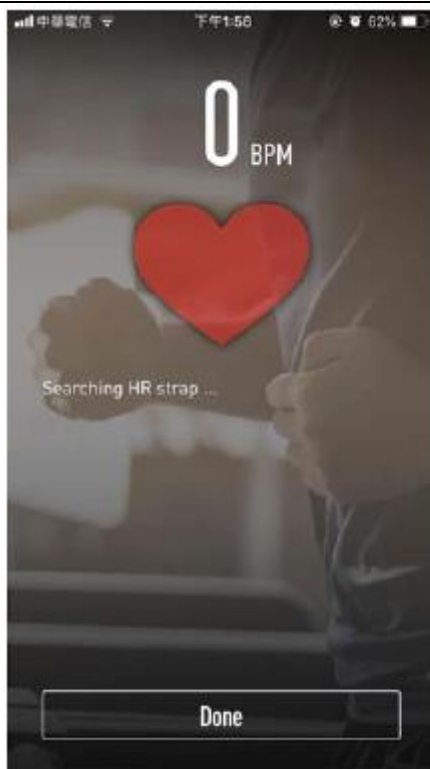

Select source: Apple watch or BLE HRM

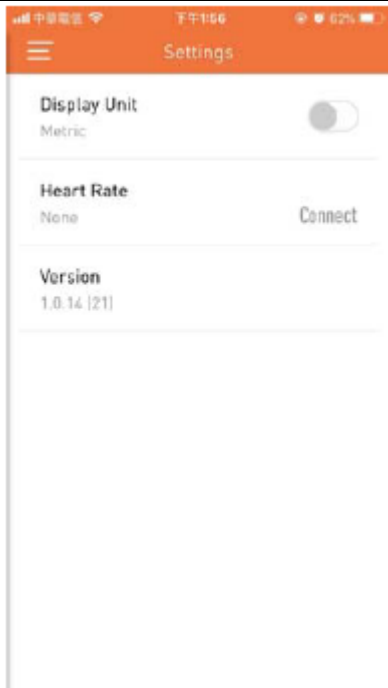

Check the program version

## QUICK START



1. Bluetooth connection: Select the device you are using. If you are using a heart rate monitor, you can select it below.
2. Once the devices are paired, click > icon in the top right corner.
3. If you cannot find the device, make sure that Bluetooth is turned on. Next connection is automatic.



4. After turning on the program, you can adjust the load or pause / stop the program.



5. Select the pin icon to pin the data.
6. When you finish the exercise a summary of the exercise is displayed. You can compare the results with previous workouts.



## INTERVAL



1. You can select the number of repetitions (interval cycles) (number in green circle), time (exercise time and rest time), level, target RMP, select go to start the program

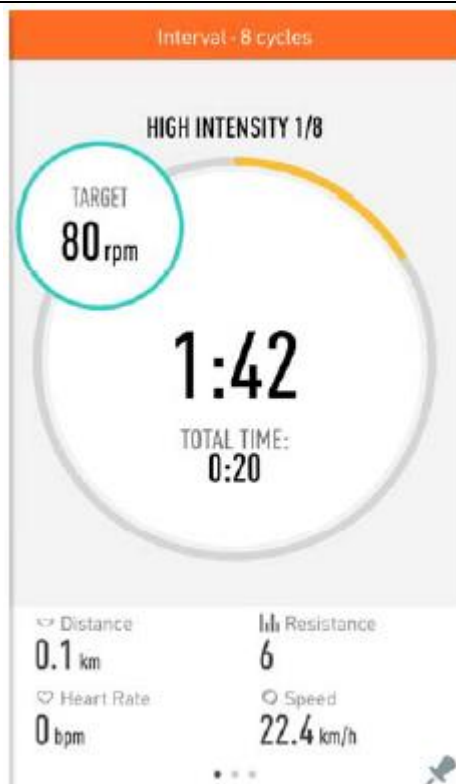

2. After turning on the program, you can set the load or pause / stop the program.



3. Select the pin icon to pin the data.

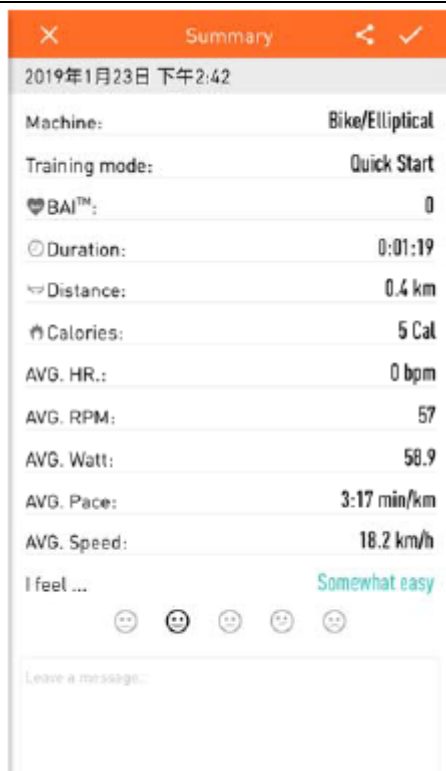

4. When you finish the exercise a summary of the exercise is displayed. You can compare the results with previous workouts.

## MAP MY ROUTE



1. Select a location.
2. Select a start point.
3. Select the route and swipe the yellow GO button to the left. You can reset the route with the green button.



4. If you do not want to set the route yourself, you can select one of the preset routes. You can choose between China routes or worldwide routes.



5. After turning on the program, you can set the load or pause / stop the program.
6. Select the arrows to show or hide the menu. Select the diamond icon to change the map view.
7. When you finish the exercise a summary of the exercise is displayed. You can compare the results with previous workouts.

# CONSTANT POWER

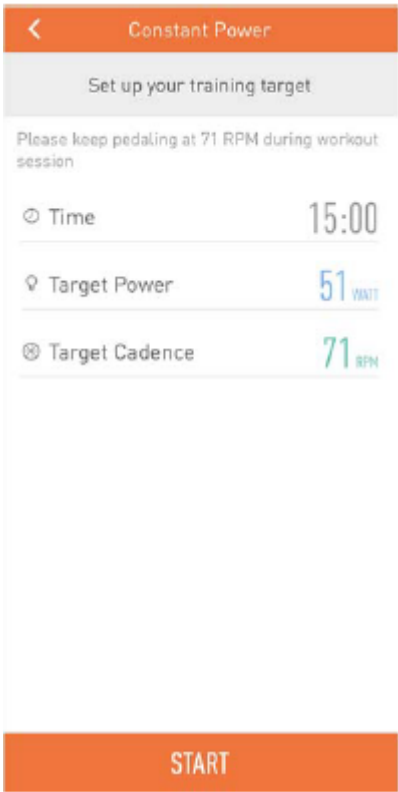

- 1. After pairing with Bluetooth, set time, target power, target RPM, target cadence



- 2. Training graphs are displayed, select one of the two graphs (Cadence / Power). The following information is displayed or by pinned with the pin button



3. Touch the display to pause or stop the training.

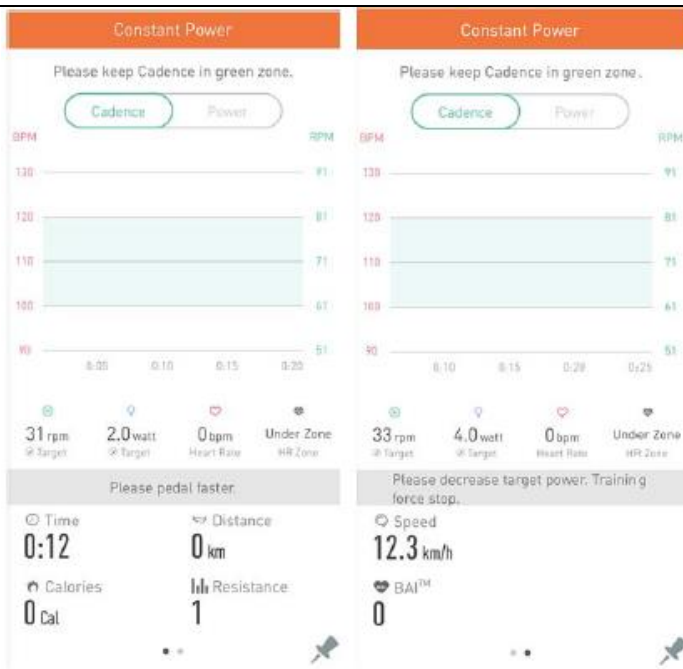

4. Workout at constant speed.

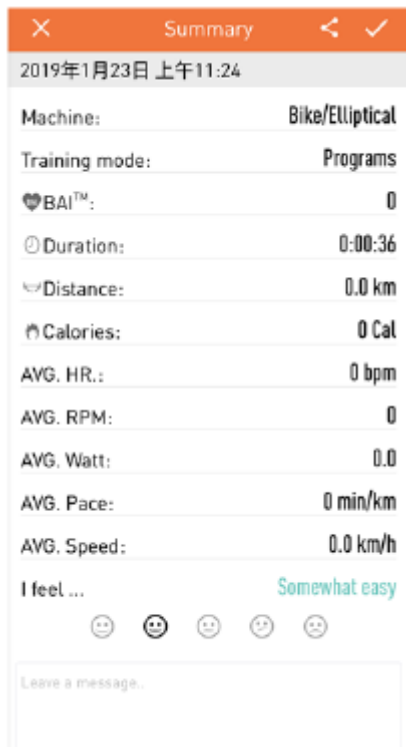

- When you finish the exercise a summary of the exercise is displayed. You can compare the results with previous workouts.

## PROGRAMS

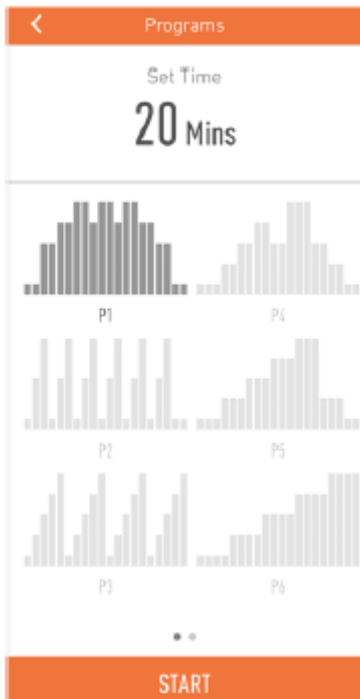

- After pairing with Bluetooth, select the program. 12 preset programs are displayed.

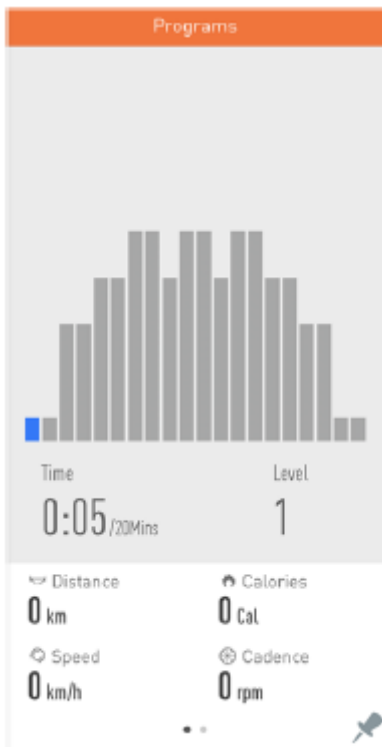

2. The display shows the progress of the training.
3. Select the pin icon to pin the data.

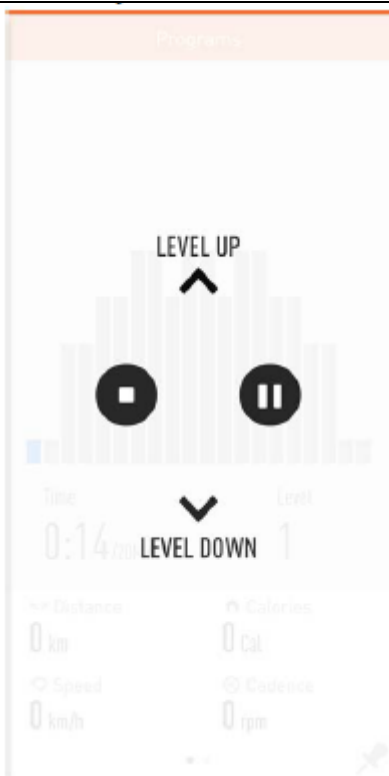

4. Touch the screen to stop or pause the program or select the load.

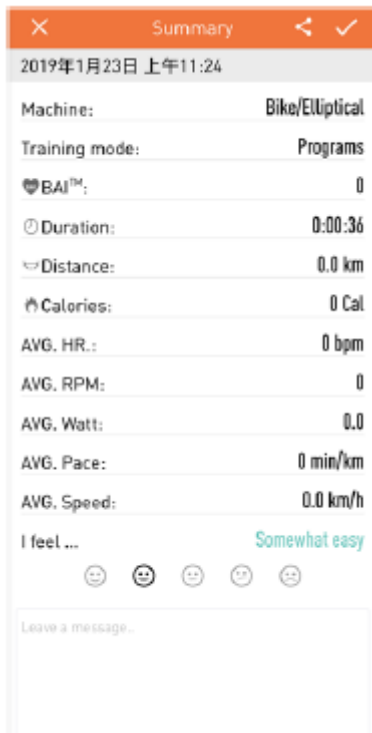

5. When you finish the exercise a summary of the exercise is displayed. You can compare the results with previous workouts.

## AI TRAINING

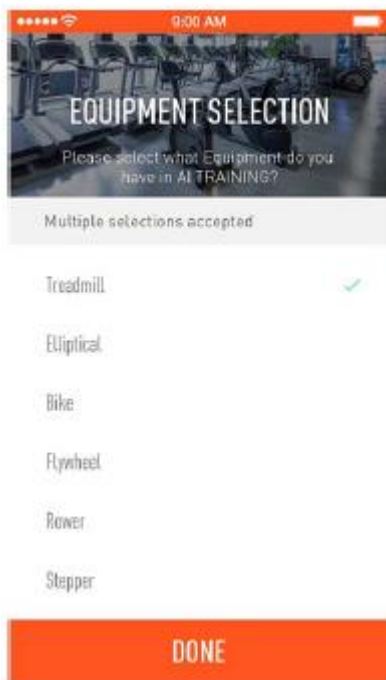

1. After pairing with Bluetooth, select the machine (you can select multiple machines).



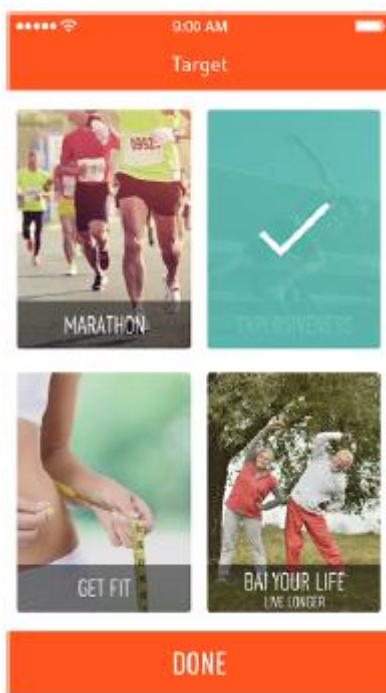

2. Select your goal / program

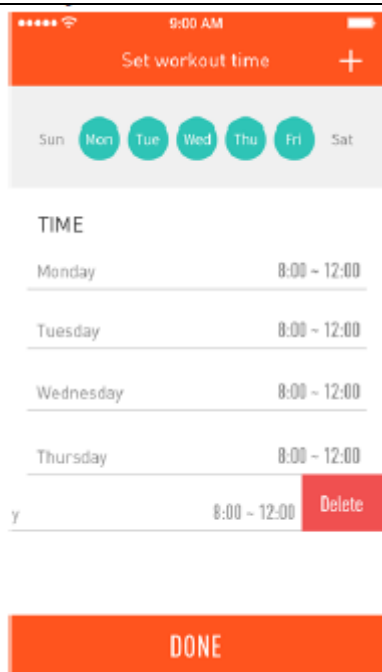

3. Set your schedule.

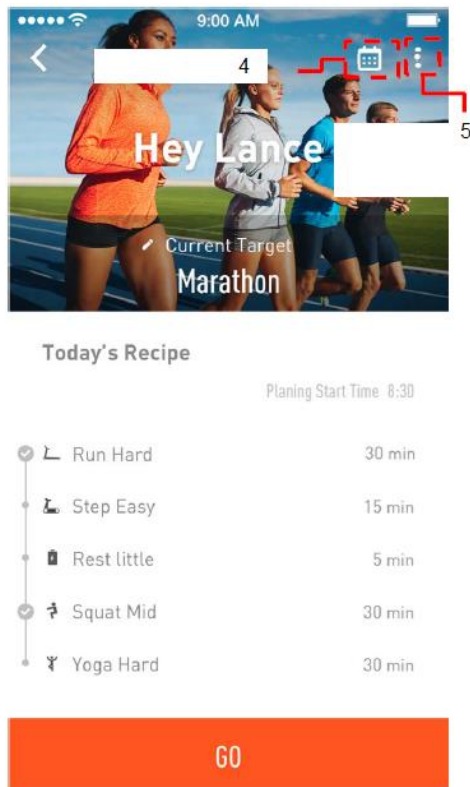

4. Training Overview

5. Training time, machine and goal / program change

## GYM CENTER

In GYM CENTER, the user can download various training programs.

1. Download the selected program
2. Turn on iRoute + program
3. For iRoute + (Google Maps) training, the user must have wifi on and be logged in.

## USE OF ELEPTICAL TRAINER

The elliptical trainer is a popular fitness machine, one of the newest and most effective home training machines.

When you are exercising on an elliptical treadmill, your feet move along the elliptical curve.

The elliptical treadmill is a frequent replacement for exercise bikes and treadmills because it is gentler for your joints. With the handles, you are also exercising the upper half of your body.

During exercise, you transfer the weight from one foot to the other. Try to maintain an upright and natural position. Handlers will help you. Find the perfect place to hold the grip and try to move as naturally as possible.

## EXERCISE INSTRUCTIONS

Exercise is beneficial to your health, improves physical condition, shapes muscles and, in combination with a calorie-balanced diet, leads to weight loss.

### 1. WARM UP

This phase serves to improve the blood circulation of the whole body and to warm up the muscles, to reduce the risk of convulsions and muscle injury. We recommend performing the stretching exercises below. When dragging, stay in the end position for approximately 30 seconds, do not make sudden movements and do not vibrate.

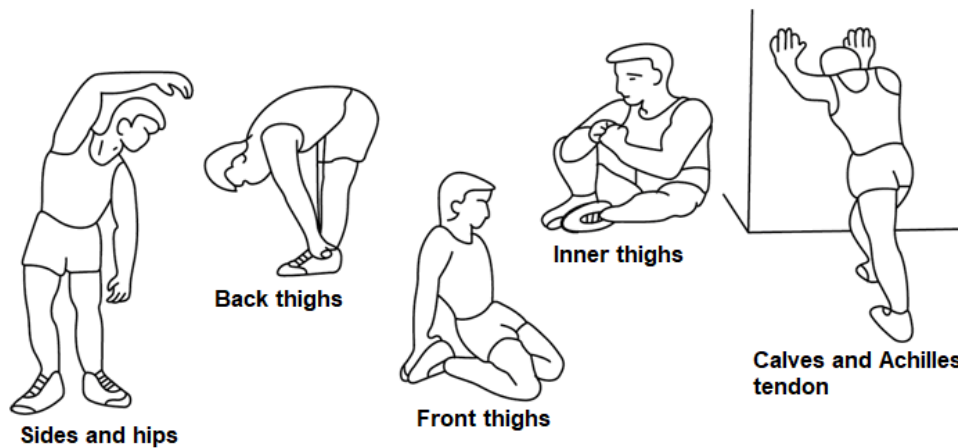

## 2. EXERCISING

This phase is the most physically demanding part. Regular exercise strengthens the muscles. You can determine the tempo yourself, but it is very important that it is the same throughout the exercise. Heart rate should be within the target zone (see figure below).

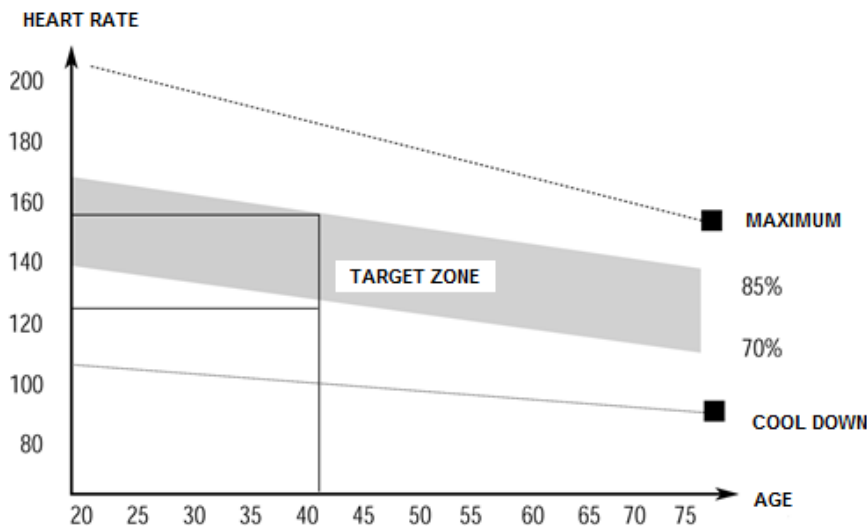

**This phase should last at least 12 minutes. Most people exercise for 15-20 minutes.**

## 3. COOLDOWN

This phase serves to soothe the cardiovascular system and relax the muscles. It should take approximately 5 minutes. You can repeat warming up exercises or continue exercising at slower pace. Stretching your muscles after exercise is extremely important - you need to avoid sudden movements and vibrations.

With improved fitness, you can lengthen and increase exercise intensity. Train regularly, at least three times a week.

## SHAPING MUSCLES

For muscle shaping, it is important to set a high load. The muscles will be more stressed, which may cause that you will not be able to exercise as long as usual. If you are trying to improve your condition at the same time, you need to adjust your training. Exercise in the usual way during the warm-up and final stages of training but increase the resistance of the device at the end of the exercise. You may need to slow down the speed to keep the heart rate in the target area.

## WEIGHT LOSS

The number of calories burned depends on the length and intensity of the exercise. The essence is the same as in fitness exercise, but the goal is different.

## MAINTENANCE

- Use only a soft cloth and a mild detergent.
- Do not clean the plastic parts with abrasives or solvents.
- Wipe the sweat after each use.
- Protect the device from moisture and extreme temperatures.
- Protect your device, computer and console from direct sunlight.
- Check the tightening of all bolts and nuts regularly.
- Store in a dry and clean place away from children.

## ENVIRONMENT PROTECTION

After the product lifespan expired or if the possible repairing is uneconomic, dispose it according to the local laws and environmentally friendly in the nearest scrapyard.

By proper disposal you will protect the environment and natural sources. Moreover, you can help protect human health. If you are not sure in correct disposing, ask local authorities to avoid law violation or sanctions.

Don't put the batteries among house waste but hand them in to the recycling place.

## TERMS AND CONDITIONS OF WARRANTY, WARRANTY CLAIMS

### General Conditions of Warranty and Definition of Terms

All Warranty Conditions stated here under determine Warranty Coverage and Warranty Claim Procedure. Conditions of Warranty and Warranty Claims are governed by Act No. 89/2012 Coll. Civil Code, and Act No. 634/1992 Coll., Consumer Protection, as amended, also in cases that are not specified by these Warranty rules.

The seller is SEVEN SPORT s.r.o. with its registered office in Strakonická street 1151/2c, Prague 150 00, Company Registration Number: 26847264, registered in the Trade Register at Regional Court in Prague, Section C, Insert No. 116888.

According to valid legal regulations it depends whether the Buyer is the End Customer or not.

“The Buyer who is the End Customer” or simply the “End Customer” is the legal entity that does not conclude and execute the Contract in order to run or promote his own trade or business activities.

“The Buyer who is not the End Customer” is a Businessman that buys Goods or uses services for the purpose of using the Goods or services for his own business activities. The Buyer conforms to the General Purchase Agreement and business conditions.

These Conditions of Warranty and Warranty Claims are an integral part of every Purchase Agreement made between the Seller and the Buyer. All Warranty Conditions are valid and binding, unless otherwise specified in the Purchase Agreement, in the Amendment to this Contract or in another written agreement.

### Warranty Conditions

#### Warranty Period

The Seller provides the Buyer a 24 months Warranty for Goods Quality, unless otherwise specified in the Certificate of Warranty, Invoice, Bill of Delivery or other documents related to the Goods. The legal warranty period provided to the Consumer is not affected.

By the Warranty for Goods Quality, the Seller guarantees that the delivered Goods shall be, for a certain period of time, suitable for regular or contracted use, and that the Goods shall maintain its regular or contracted features.

### Batteries

6-month battery warranty – we guarantee that battery's nominal capacity does not fall below 70% of its total capacity within 6 months of the product's sale.

**The Warranty does not cover defects resulting from (if applicable):**

- User's fault, i.e. product damage caused by unqualified repair work, improper assembly, insufficient insertion of seat post into frame, insufficient tightening of pedals and cranks
- Improper maintenance
- Mechanical damages
- Regular use (e.g. wearing out of rubber and plastic parts, moving mechanisms, joints, wear of brake pads/blocks, chain, tires, cassette/multi wheel etc.)
- Unavoidable event, natural disaster
- Adjustments made by unqualified person
- Improper maintenance, improper placement, damages caused by low or high temperature, water, inappropriate pressure, shocks, intentional changes in design or construction etc.

**Warranty Claim Procedure**

The Buyer is obliged to check the Goods delivered by the Seller immediately after taking the responsibility for the Goods and its damages, i.e. immediately after its delivery. The Buyer must check the Goods so that he discovers all the defects that can be discovered by such check.

When making a Warranty Claim the Buyer is obliged, on request of the Seller, to prove the purchase and validity of the claim by the Invoice or Bill of Delivery that includes the product's serial number, or eventually by the documents without the serial number. If the Buyer does not prove the validity of the Warranty Claim by these documents, the Seller has the right to reject the Warranty Claim.

If the Buyer gives notice of a defect that is not covered by the Warranty (e.g. in the case that the Warranty Conditions were not fulfilled or in the case of reporting the defect by mistake etc.), the Seller is eligible to require a compensation for all the costs arising from the repair. The cost shall be calculated according to the valid price list of services and transport costs.

If the Seller finds out (by testing) that the product is not damaged, the Warranty Claim is not accepted. The Seller reserves the right to claim a compensation for costs arising from the false Warranty Claim.

In case the Buyer makes a claim about the Goods that is legally covered by the Warranty provided by the Seller, the Seller shall fix the reported defects by means of repair or by the exchange of the damaged part or product for a new one. Based on the agreement of the Buyer, the Seller has the right to exchange the defected Goods for a fully compatible Goods of the same or better technical characteristics. The Seller is entitled to choose the form of the Warranty Claim Procedures described in this paragraph.

The Seller shall settle the Warranty Claim within 30 days after the delivery of the defective Goods, unless a longer period has been agreed upon. The day when the repaired or exchanged Goods is handed over to the Buyer is considered to be the day of the Warranty Claim settlement. When the Seller is not able to settle the Warranty Claim within the agreed period due to the specific nature of the Goods defect, he and the Buyer shall make an agreement about an alternative solution. In case such agreement is not made, the Seller is obliged to provide the Buyer with a financial compensation in the form of a refund.

**CZ  
SEVEN SPORT s.r.o.**

Registered Office: Strakonická 1151/2c, Praha 5, 150 00,  
ČR  
Headquarters: Dělnická 957, Vítkov, 749 01  
Warranty & Service: Čermenská 486, Vítkov 749 01  
CRN: 26847264  
VAT ID: CZ26847264

**About shipping**

Phone: +420 556 300 970  
E-mail: eshop@insportline.cz  
reklamace@insportline.cz  
servis@insportline.cz

Web: www.inSPORTline.cz

**SK**  
**inSPORTline s.r.o.**

Headquaters, warranty & service center: Električná 6471,  
Trenčín 911 01, SK

CRN: 36311723  
VAT ID: SK2020177082

Phone: +421(0)326 526 701  
E-mail: objednavky@insportline.sk  
reklamacie@insportline.sk  
servis@insportline.sk

Web: www.inSPORTline.sk

